

Request for Proposals
NANTASKET GAZEBO PROJECT – Phase II Gazebo Construction
AT NANTASKET BEACH HULL, MASSACHUSETTS

The Hull Redevelopment Authority (HRA) invites competitive bids under M.G.L. c. 149 from qualified contractors to construct a gazebo on a pre-prepared site in Hull, Massachusetts. Funding is provided through the Hull Redevelopment Authority (HRA).

Complete specifications and proposal requirements will be available beginning February 14, 2019 and can be obtained by contacting Chris DiIorio at chris@hra02045.com or by mail/in person at: Community Development and Planning Office, Town Hall 2nd Floor; 253 Atlantic Avenue; Hull, MA 02045.

Proposals must be received no later than 2:00 P.M. on March 11, 2019 in the manner and format as required in the Request for Proposals, and should be addressed to the Hull Redevelopment Authority C/O Chris DiIorio at the above stated Community Development and Planning address. The HRA reserves the right to waive any informality in the proposal procedure, to cancel this Request for Proposal or to reject any and all proposals received deemed not in the best interest of the HRA.

The HRA encourages Women and Minority-owned businesses to submit proposals.

The Hull Redevelopment Authority (hereafter referred to as HRA) undertaking a project to construct a gazebo on HRA owned property west of Nantasket Avenue between Bay Street and Edgewater Road. The project includes the construction of an approximately 24 foot wide octagonal gazebo on a concrete pad with a 440' long ADA compliant walkway.

The project will be constructed in two phases. The HRA intends to release separate RFP's and enter into independent contracts for Phase I and Phase II. It is expected that if there are separate contractors for each phase that there will be substantial coordination between the two parties during the Phase I design process.

Phase I will provide for site preparation and includes the design and construction of a foundation and ADA compliant concrete walkway leading to the foundation.

Phase II provides for the construction (constructed on site or prefabricated and installed) of a gazebo on the previously constructed foundation.

I. Introduction and Project Description

The HRA is seeking qualified contactors to construct a gazebo defined as Phase II of the project.

The contractor is to provide a detailed proposal including a schedule, cost estimates, and evidence of the ability to complete construction of the gazebo structure in accordance with the scope of services and specifications as detailed in this RFP.

The HRA will evaluate proposals, conduct interviews if needed and select a contractor to undertake the work. The HRA, the Director of the Building Department, the Director of Community Development and other Municipal staff as needed will provide input and review work products during project implementation.

II. General Instructions

A. Specifications

Contractors shall submit a proposal in accordance with the terms and conditions in these General Instructions, Section III - Required Elements of the Proposal Package, Attachment 1 - Scope of Services and the required forms attached to this RFP.

This RFP for Phase II is for the construction/installation of a gazebo based on the Attachment 2 - Specifications

B. Project Schedule

The HRA anticipate issuing the contract award for Phase I and II concurrently as indicated in Attachment 3. Phase I permitting and development of the site including a concrete pad for the gazebo will start-up

immediately following the award based on plans and specs provided by the HRA. Upon completion Phase II shall begin. The proposed schedule for the entire project is presented in Attachment 3.

C. Project Fee

Contractors must complete Attachment 4 - Fee Proposal Form. Fees shown shall include all costs and expenses (including but not limited to copying, mileage, photographs, etc.) to complete the Scope of Services.

D. Questions

Any questions regarding this proposal shall be directed to Chris DiIorio at chris@hra02045. The deadline for questions is indicated in Attachment 3. All questions will be answered in a document to be provided to all potential applicants that have requested these RFP materials.

E. Site Visit

The site visit will be held on the date indicated on Attachment 3 at a time to be determined.

F. Submissions

All responses must be delivered or mailed to the address below. However, the HRA is not responsible for inaccurate submittals or if submittals are not received in a timely way. All responses must be clearly marked with "Nantasket Gazebo Project - Phase II Construction, and delivered or mailed to the following address:

Hull Redevelopment Authority
C/O Chris DiIorio
Community Development and Planning Office
253 Atlantic Avenue
Hull, MA 02045

Proposals are due at 2:00 P.M. on March 11, 2019, at which time the Proposals will be recorded in a Registry which will be made available to the public. The proposals will be opened and bid price identified. The Proposals will be distributed to the Evaluation Committee.

G. Proposal Corrections, Modifications and Withdrawals

Prior to the date of the opening, Contractors may correct, modify, or withdraw their proposals. Any correction or modification must be submitted in writing in a clearly marked, sealed envelope. Requests for withdrawals must be submitted in writing. All proposals and cost amounts will be considered firm and may not be withdrawn for a period of sixty (60) days from the date of the proposal opening unless stated otherwise.

III. Required Elements of a Proposal Package

Format

Contractors must submit an original and eight (8) copies, for a total of nine (9) sets of sealed Proposal packages.

Proposal packages must contain all elements and requirements stated below.

The complete proposal must be placed in a separate sealed envelope, which clearly indicates the Contractor's name and address. The submittal must be marked with the following legend:

HRA - Contracting Services For, "Nantasket Gazebo Project – Phase II Construction"

Required Content

The proposal must include the following information supporting the Contractor's ability in providing the required services:

1. **Complete and submit the following attached forms in Attachments 4 and 5:**
 - a. Fee Proposal Form
 - b. Certificate of Non-Collusion
 - c. Tax Compliance Certification
 - d. Description of Applicant Business/Organization
 - e. Certificate of Vote/Signature

2. **Provide the identity of the individual, partnership or corporation applying for contract award.**

If the applicant is a partnership or joint venture, the proposal should specify who would act as the representative for purposes of assuming contractual responsibility. If the Contractor intends to subcontract any work required in the Scope of Services, all Sub-Contractors must be identified in the proposal. Experience in working with named Sub-Contractors should be included.

3. **An applicant qualifications statement, including professional work experience attesting to capacity to perform the required work program.**

Provide an applicant qualifications statement, including licenses, registrations, and professional work experience attesting to capacity to perform the required work program.

The Applicant must submit names and qualifications of the key individuals who will be used on this Project. Describe their background and experience in similar projects. Detail the names, qualifications, and experience of each Sub-Contractor proposed to be used in this Project.

4. **A description of the Contractor's approach to this project.**

Methodology, demonstrated understanding of the project needs, and the Contractor's expectations of assistance and services from the HRA must be clearly detailed. Proposed modifications to the attached plans or materials shall be clearly identified.

5. **An estimated project timeline showing contract deliverable milestones.**

Include a clearly defined proposal and timeline for working in conjunction with the contractor for Phase I of the project. The selected Contractor will update this timeline periodically.

6. A description of experience on similar projects

Describe similar completed projects. For each project, include name and telephone number of contact person, location, description of project, cost, date of completion, and names of key personnel involved in the project. Contractors' references may be contacted by the HRA as deemed appropriate.

7. Insurance

Each Contractor responding to the Request for Proposals shall submit a "Certificate of Insurance" for the items listed below. If insurance meeting these requirements is not currently in effect, the applicant must provide clear evidence that such coverage can be obtained. Arrangements shall be made with each insurance company to notify the HRA of any termination or material change in the aforementioned insurance at least ten (10) days prior to the date on which the termination or change takes place.

<u>Type of Insurance</u>	<u>Minimum Coverage</u>
Comprehensive General Liability with broad form Comprehensive Liability endorsement and auto (non-owned and hired)	\$1,000,000
Worker's Compensation and Employer's Liability	\$1,000,000
Automotive Liability (owned and non-owned used in conjunction with the job both on and off the highway) injury and property damage	\$1,000,000

The HRA and the Town of Hull, shall be named as additional insured in all liability policies.

8. Bid Surety

All general bids shall be accompanied by a bid deposit in the form of a certified, cashier's or treasurer's check (no cash) issued by a responsible bank or trust company made payable to the Hull Redevelopment Authority or a bid bond. The amount shall be no less than 10% of the value of the bid.

9. Price Proposal

Prevailing Wage rates as set forth by the State of Massachusetts must be paid on this project.

Complete the Price Proposal. All Price Proposals must be submitted on forms furnished in Attachment 4 of this Request For Proposals. Proposals submitted on any other form will not be accepted as valid.

IV. Selection/Evaluation Criteria

1. The contract will be awarded to the responsible and qualified contractor offering to perform the contract at the lowest price.
2. The successful low bidder will be required to furnish a **Performance Bond and a Labor and Material (Payment) bond** each in the amount of one hundred percent (100%) of the contract sum. Bond shall be obtained from a surety licensed to do business in the Commonwealth of Massachusetts and the form shall be satisfactory to the Hull Redevelopment Authority.
3. **Local harmony and OSHA training certifications:** The successful low bidder shall provide with the contract, certifications regarding labor harmony and training approved by the U.S. Occupational Safety and Health Administration to be completed by all employees to be employed at the worksite.

V. General Provisions

The HRA reserves the right to reject any or all proposals, or parts of proposals, to solicit new proposals and to award contracts as it deems to be in its best interest. The selected Contractor must comply with all applicable municipal, state and federal laws and regulations in performance of services.

All plans and other documents and electronic files resulting from this Contract shall become the property of the HRA.

The selection of the successful Contractor shall be made without regard to race, color, sex, age, religion, political affiliation or national origin.

The HRA is an Affirmative Action/Equal Opportunity Employers. The HRA encourages proposals from qualified minority and women's business enterprises. Potential Contractors are hereby notified that issuance of this Request for Proposals and receipt of proposals does not assure that a Contractor will be chosen. Selection is dependent upon funding availability and the Hull Redevelopment Authority's priorities. The HRA will select the responsive and responsible Contractor submitting the most advantageous proposal, taking into consideration the Contractor's experience, staff capacity, references and plan for providing the services, as well as the proposal price. If necessary the Contractor's plan of services will be negotiated with the selected finalist. If an agreement cannot be reached with the selected finalist, the HRA will contact the second highest-ranking firm, as determined by the HRA, and commence negotiations with that Contractor. Contractors will bear all costs and expense in preparing their proposal and executing a Contract with the Hull Redevelopment Authority.

ATTACHMENT 1
Scope of Services

Permitting (to be performed by others with assistance from Contractor)

Site Work and Foundation Construction (to be performed by others with input from Contractor)

Gazebo Construction (to be performed by Contractor)

Enter into a contract for the construction of the gazebo project.

Contractor shall conform to all standards outlined in Massachusetts Procurement Law including Prevailing Wage and Payment Bond requirements.

Construct the gazebo in accordance with the final approved plan set.

The contractor will work closely with the contractor selected to provide the foundation of the gazebo to ensure the two projects will be coordinated.

Attending various meetings with the HRA, city staff and other contractors involved to review and coordinate the project.

Assist the HRA in the permitting of the project. HRA will be the lead, but the Contractor may be called upon to attend meetings, provide necessary documents, modify plans, or assist in the process in other ways.

Conduct a pre-construction meeting with HRA and city staff, outline project wage rates, state and federal regulations that apply, project timetable and budget.

Maintain contact with the HRA and city staff during construction.

Coordinate project supervision with city staff and/or resident inspector during construction.

Maintain a clean and organized work area.

Provide payment invoices that detail work completed, work to be completed and estimated time to complete.

ATTACHMENT 2
Specifications

Please see attached drawings with notes for design specifications and details

The structure shall conform to all applicable codes (building, electrical, ADA, environmentalí etc)

All timber exposed to weather to be pressure-treated lumber, painted with quality outdoor paint
Decking, stair treads, railings, columns and remaining trim work are to be composite/vinyl materials

Electrical Work is to be performed by a licensed electrician and approved by the Town.

Benches shall be installed with the contractor to identify construction style and location.

**ATTACHMENT 3
Project Schedule**

Project/Task	Date
Issue RFP: Submit Notice to the Central Register, COMMBUYS, Hull Times, post notice at Town Hall and on website. Solicit written responses from three contractors who customarily perform this work.	2/14/19
RFP Available for Distribution	2/14/19
Site Visit	2/26/19
Question Deadline	3/4/19
Contractor Proposals Submitted: Contractors submit proposals. HRA (Selection Committee) independently review and rank proposals in accordance with established criteria.	3/11/19
Selection Committee meets to Review Proposals: Convenes to discuss proposals and rankings, and identify preferred contractor open price proposals and conduct reference checks (determine if interviews needed)	3/11/19
Interview may be required of selected Contractors	3/18/19
Contractor Award	3/18/19
Start Construction Phase I (Including Permitting of the Project ó HRA will be the lead in obtaining permits)	3/25/19
End Construction Phase I	5/15/19
Start Construction Phase II	5/15/19
End Construction Phase II	6/15/19

ATTACHMENT 4

FEE PROPOSAL FORM

The undersigned proposes to furnish all professional services necessary to complete The Hull Redevelopment Authority's **Nantasket Gazebo Project - PHASE II Construction**, project as detailed in Attachment 1 -Scope of Services and Attachment 2 Gazebo Specifications for the Contracted Price specified below. The specified Contracted Price includes all fees and reimbursable costs and expenses necessary to complete the Scope of Services as defined in Attachment 1 of this RFP including but not limited to all Subcontractors, meeting related costs, printing, copying, mileage, photographs, etc.

Project fees must be provided for each Project Component of work as described in the Scope of Services. The lowest bid price will be the lowest bid price for Total Design/Engineering Cost.

The proposed total contract price is:

_____ (\$ _____)
(Amount in Words)

The undersigned certifies under the penalties of perjury that this proposal has been submitted and made in good faith and without collusion or fraud with any other person. As used in this section, the word "person" shall mean any natural person, joint venture, partnership, corporation, or other business or legal entity.

Date: _____

By: _____

(Name/Title of person signing proposal)

(Company)

(Business Address)

ATTACHMENT 5

REQUIRED FORMS TO BE INCLUDED IN THE TECHNICAL PROPOSAL

- a. Certificate of Non-Collusion**
- b. Tax Compliance**
- c. Description of Applicant Business/Organization**
- d. Certificate of Vote/Signature**

CERTIFICATE OF NON-COLLUSION

The undersigned certifies under penalties of perjury that this quote has been made and submitted in good faith and without collusion or fraud with any other person. As used in this certification, the word "person" shall mean any natural person, business, partnership, corporation, union, committee, club, or other organization, entity, or group of individuals.

(Signature of individual submitting proposal) (Name of Business)

Subscribed and sworn to this _____ day of _____, 2019,

Before me,

(Notary Public) (Date Commission Expires)

TAX COMPLIANCE CERTIFICATION

Pursuant to M.G.L. c. 62C, §49A, I certify under the penalties of perjury that, to the best of my knowledge and belief, I am in compliance with all laws of the Commonwealth relating to taxes, reporting of employees and contractors, and withholding and remitting child support.

(Signature of individual submitting proposal)

(Name of Business)

Subscribed and sworn to this _____ day of _____, 2019,

Before me,

(Notary Public)

(Date Commission Expires)

DESCRIPTION OF APPLICANT BUSINESS/ORGANIZATION

Check appropriate line(s):

The named organizational entity submitting this proposal is:

Corporation _____ Partnership _____ Proprietorship _____
Minority Owned _____ Woman Owned _____

SIGNATURES:

This page must be signed by a (n) individual(s) with authority to commit the proposing entity to a binding agreement. Corporations must attach required certification:

COMPANY NAME: _____

AUTHORIZED SIGNATURE: _____

PRINT NAME OF AUTHORIZED OFFICIAL: _____

ADDRESS: _____

TELEPHONE NUMBER: _____ FAX NUMBER: _____ EMAIL: _____

DATE: _____

FEDERAL TAX ID #: _____

A notarized attestation of the signature(s) is required, or in the case of corporate seal affixed, that the signature is the signature of an officer authorized to bind the corporation to a contractual agreement.

CERTIFICATE OF VOTE/SIGNATURE

I, _____, Clerk of _____, hereby certify that, at a meeting of the Board of Directors of said Corporation duly held on _____, at which a quorum was present and voting throughout, the following vote was duly passed and is now in full force and effect:

ŃVOTED: That _____
(NAME OF OFFICER AUTHORIZED TO SIGN FOR CORPORATION)

be and hereby is authorized, directed and empowered for, in the name and on behalf of this Corporation to sign, seal with the corporation seal, execute, acknowledge and deliver all contracts, bonds, and other obligations of this Corporation: the execution of any such contract, bond or obligation by such _____ to be valid and binding upon this Corporation for all purposes, and that a
(NAME OF OFFICER)

certificate of the Clerk of this Corporation setting forth this vote shall be delivered to The Hull Redevelopment Authority; and that this vote shall remain in full force and effect unless and until the same has been altered, amended, or revoked by a subsequent vote of such directors and a certificate of such later vote attested by the Clerk binding this Corporation is delivered to The Hull Redevelopment Authority.

I further certify that _____ is the duly elected _____
(NAME OF OFFICER) (TITLE)
of said Corporation.

Signed: _____
(CLERK/SECRETARY)

Place of Business: _____

Date of Contract: _____

AFFIX CORPORATE SEAL HERE

COUNTERSIGNATURE: _____
(NAME AND TITLE OF OFFICER)

In the event that the Clerk or Secretary is the same person as the Officer authorized to sign that contract or other instrument for the Corporation, this certificate must be countersigned by another officer of the Corporation.

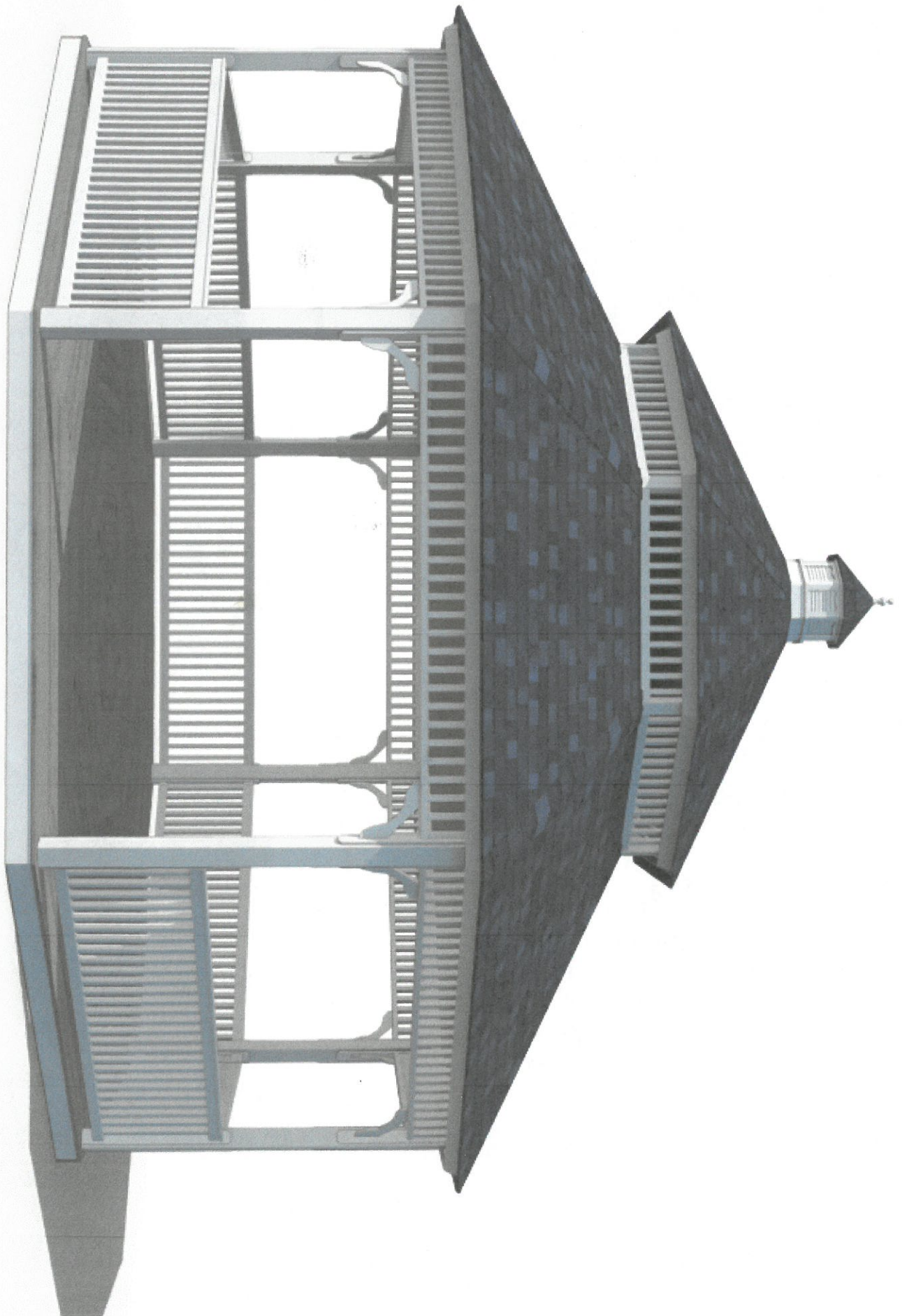

24'-28' Octagonal Pagoda Gazebos for:

Drawing Index

- Page 1- Floor Framing Plan
- Page 2- Roof Framing Plan
- Page 3- Cross Section
- Page 4- Details
- Page 5- Details

GENERAL NOTES

All notes do not necessarily apply due to different requirements on each project. This plan is intended to reflect only the structural design of this building. The contractor shall review all applicable local, state, and federal building codes prior to the start of construction to ensure building conformance. Amish Country Gazebos is not responsible for information pertaining to this project if not shown on drawings or listed below. Revisions to the plans shall be approved by engineer of record.

DESIGN REQUIREMENTS

1. Governing Code:
including, not limited to: IBC 2003, ICC Electric Code 2003, MC 2003, IFC 2003
- A. Use Group Classification U
- B. Type of Construction 5-B
2. Dead Loads:
 - A. Roof 5 pcf
 - B. Floor 10 pcf
 - C. Other n/a pcf
3. Live Loads:
 - A. Roof (See also note #5) 40 pcf
 - B. Floor 100 pcf
 - C. Other n/a pcf
4. Truss Loads:
 - A. Top Chord Live n/a pcf
 - B. Top Chord Dead n/a pcf
 - C. Bottom Chord Live n/a pcf
 - D. Bottom Chord Dead n/a pcf
5. Snow Loads:
 - A. Ground Snow (Pg) 40 pcf
 - B. Flat Roof Snow (Pf) 28 pcf
 - C. Snow Exposure Factor (Ce) 1.0
 - D. Snow Load Importance Factor (I) 1.0
 - E. Unbalanced Snow
 - i. Windward roof 0 pcf
 - ii. Leeward roof 37.8 pcf
6. Wind Load
 - A. Basic Wind Speed (V) 110 mph
 - B. Wind Load Importance Factor (I) .87
 - C. Wind Exposure Category C

ABBREVIATIONS

•	al	mil.	millimeter
bm.	beam	min.	minimum
conc.	concrete	nts	not to scale
cont.	continuous	o/c	on center
dia.	diameter	pcf	pounds per cubic foot
exist.	existing	pl.	plywood
fr.	floor	pcf	pounds per square foot
ft.	foot/feet	pci	pounds per square inch
ga.	gauge	req'd.	required
hdw.	hardware	SYP	Southern Yellow Pine
hdr.	header	ss	stainless steel
jt.	joint	st.	steel
ksi	kips per square inch	thk.	thick
lbs.	pounds	trd.	treated
max.	maximum	typ.	typical
		w/	with
		mfr.	manufacturer

WOOD

1. General Requirements
 - A. Structural wood members and connections shall be of sufficient size or capacity to carry all design loads without exceeding the allowable design values specified in "The National Design Specification for Wood Construction" (NDS), 1997 edition, and its "Supplement" by the American Forest and Paper Association (AF+PA).
 - B. Wood members used for load supporting purposes shall have the grade mark of a lumber grading agency certified by the American Lumber Standards Committee.
2. Dimension Lumber
 - A. All lumber species, graded visually or mechanically, shall comply with the NDS by AF+PA, and the "American Softwood Lumber Standard" (PS 20-94) by the U.S. Department of Commerce.
 - B. The minimum grade and species for posts, beams, headers, and other primary structural members shall be #2 Southern Pine, unless specified otherwise.
 - C. Lumber used for secondary framing shall be #2 Spruce-Pine-Fir (SPF) or better.
 - D. Post frame headers shall be two-span continuous beams with all multiple ply headers overlapping so that the butt joints for each ply do not occur at the same post.
 - E. Mechanically laminated columns shall conform with ANSI/ASAE EP 559.
3. Pressure Preservative Treatment (PPT)
 - A. Pressure treatment to be performed according to the American Wood Preservers' Association (AWPA) standards.
 - B. Pressure treated members shall have the inspection mark of an agency accredited by the American Lumber Standards Committee.
 - C. Preservative: Waterborne L.
 - D. Minimum waterborne treatment retention shall be 0.4 pcf for members above ground, and 0.6 pcf for members in contact with earth.
 - E. Treat indicated items and the following:
 1. Wood members exposed to weather or insect infestation.
 2. Wood members in direct contact with earth or concrete.
 3. Wood members exposed to high moisture content (19% for dimension lumber, 16% for glued laminated timber).
 4. Wood members less than 12 inches above grade.
 - F. Field treat newly exposed wood where cutting, drilling or notching pressure treated lumber.
 - G. Metal connectors used in treated wood shall be hot-dip galvanized as per ASTM A153-01a.
4. Connections shall be designed and constructed according to the NDS by AF+PA and shall conform to the following:
 - A. The minimum connection shall be two 12 penny nails, or as detailed on the drawings.
 - B. Other connections as per standard construction practice.

Pagoda Style Roof Specifications and Dimensions

Size	A	B	C	D	E	F	G	H	J	K
24'	311 ³ / ₄ "	288"	119 ⁵ / ₁₆ "	218 ¹ / ₁₆ "	194 ¹ / ₁₆ "	95"	42 ¹ / ₂ "	6 ¹ / ₂ "	94 ⁹ / ₁₆ "	72 ⁵ / ₈ "
28'	363 ³ / ₁₆ "	336"	139 ³ / ₁₆ "	231 ¹ / ₁₆ "	207 ¹ / ₁₆ "	95"	42 ¹ / ₂ "	6 ¹ / ₂ "	110 ⁵ / ₁₆ "	171 ³ / ₈ "

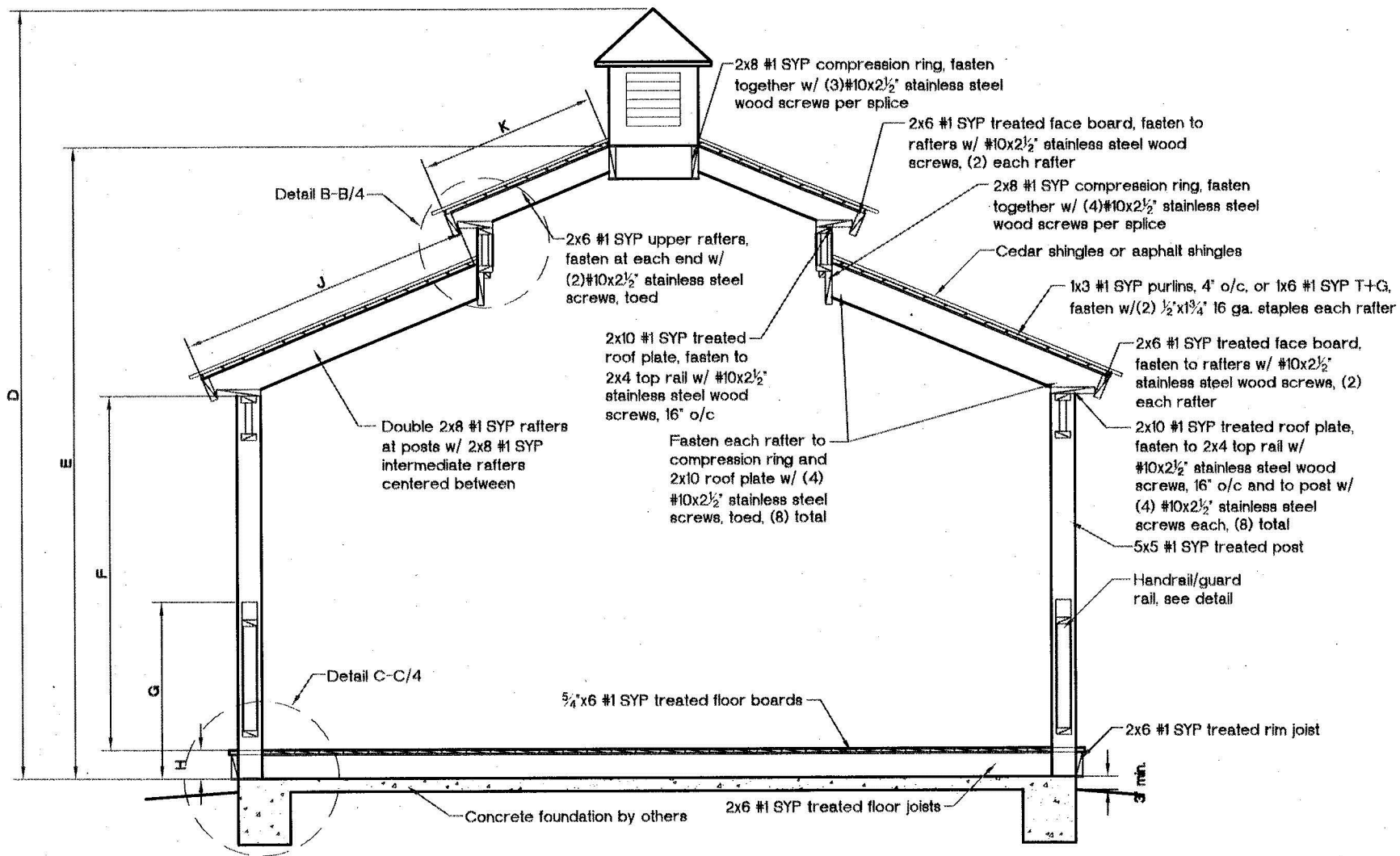

Cross Section A/3

(With floor)

NTS

DRAWING TITLE:

PROJECT:

NO.	DATE	BY

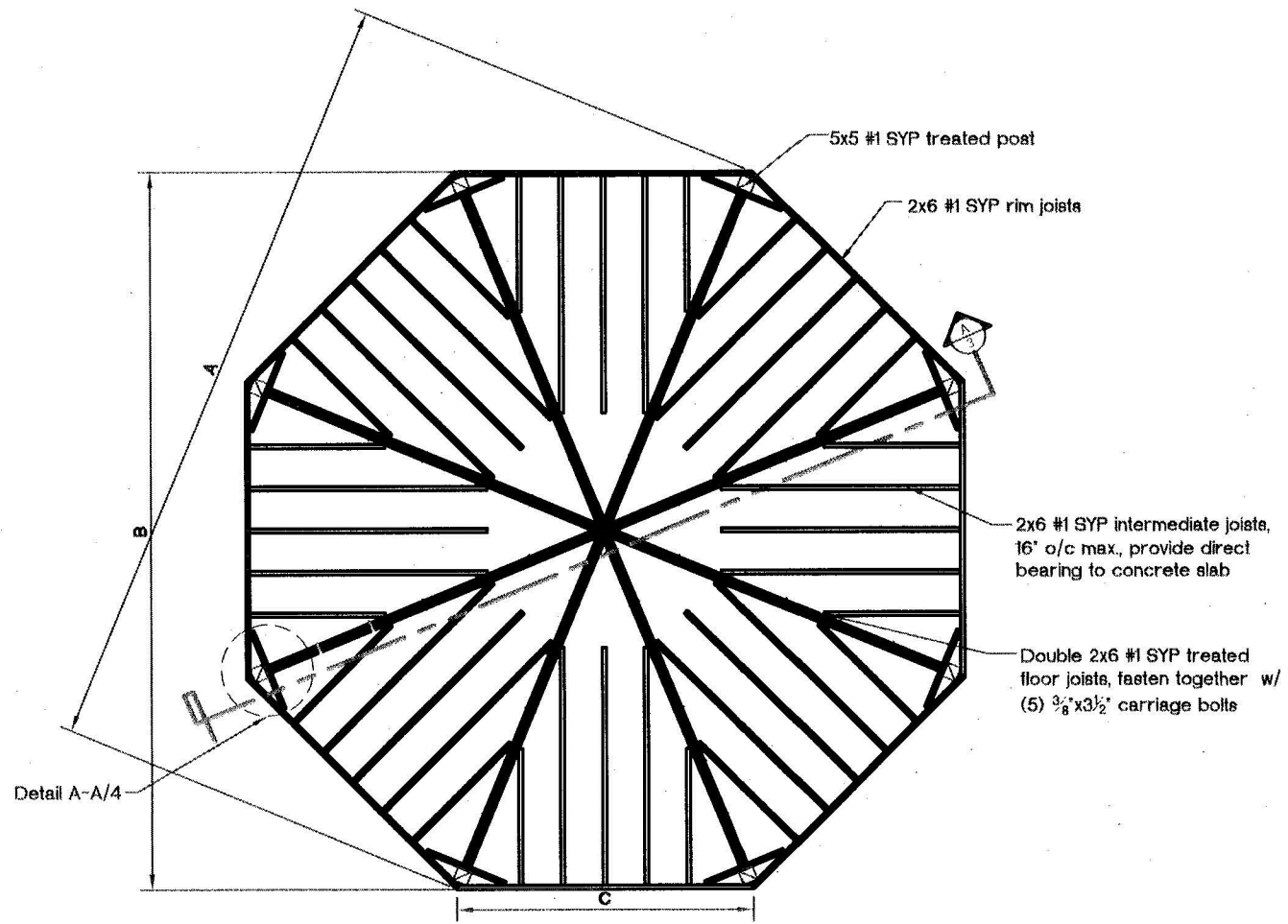

Floor Framing Plan

NTS

DRAWING TITLE:

PROJECT:

NO.	DATE	BY

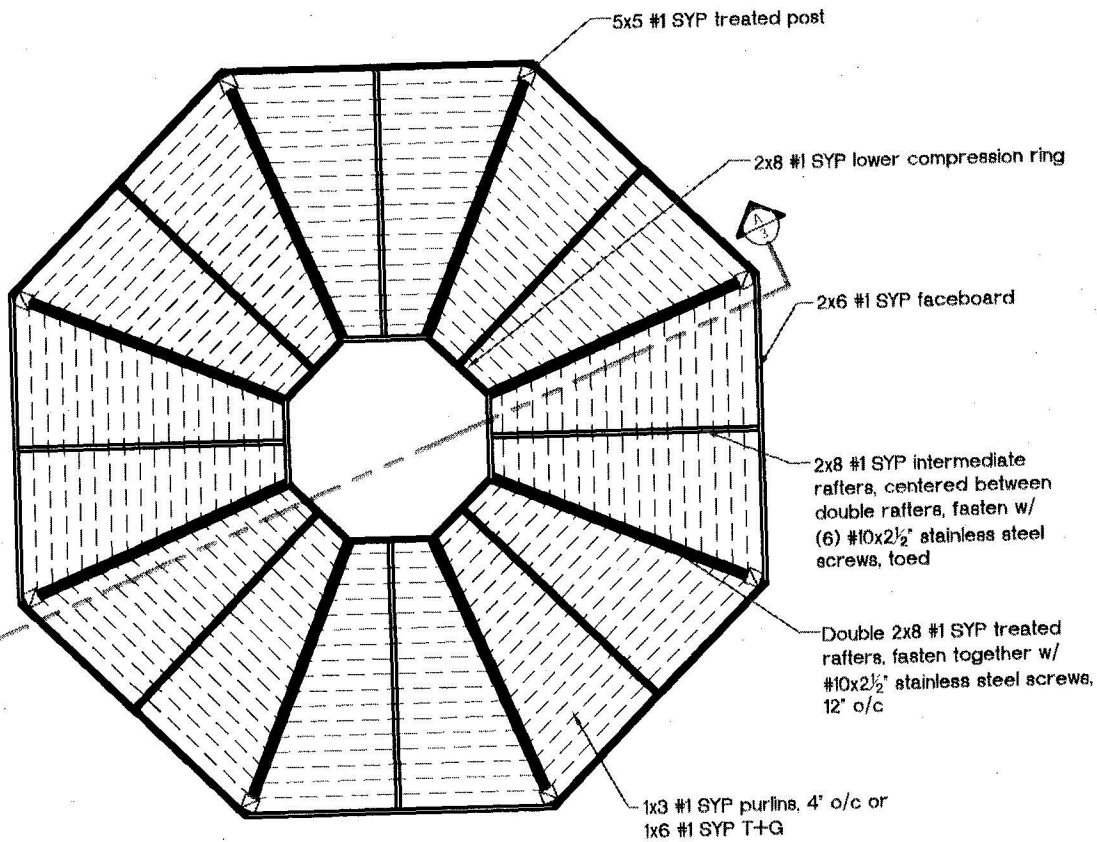

Roof Framing Plan

(Lower Roof)

NTS

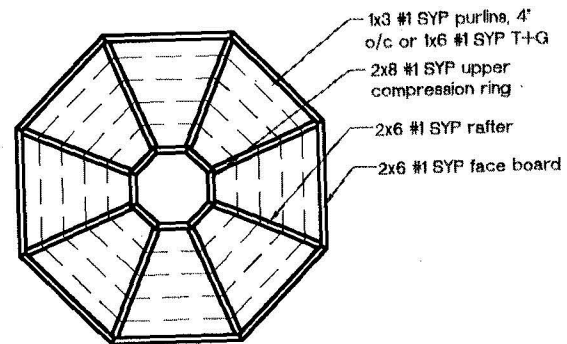

Roof Framing Plan

(Upper Roof)

NTS

DRAWING TITLE:

PROJECT:

DESIGNED BY	DATE	BY
CHECKED BY		
DATE		
SCALE		

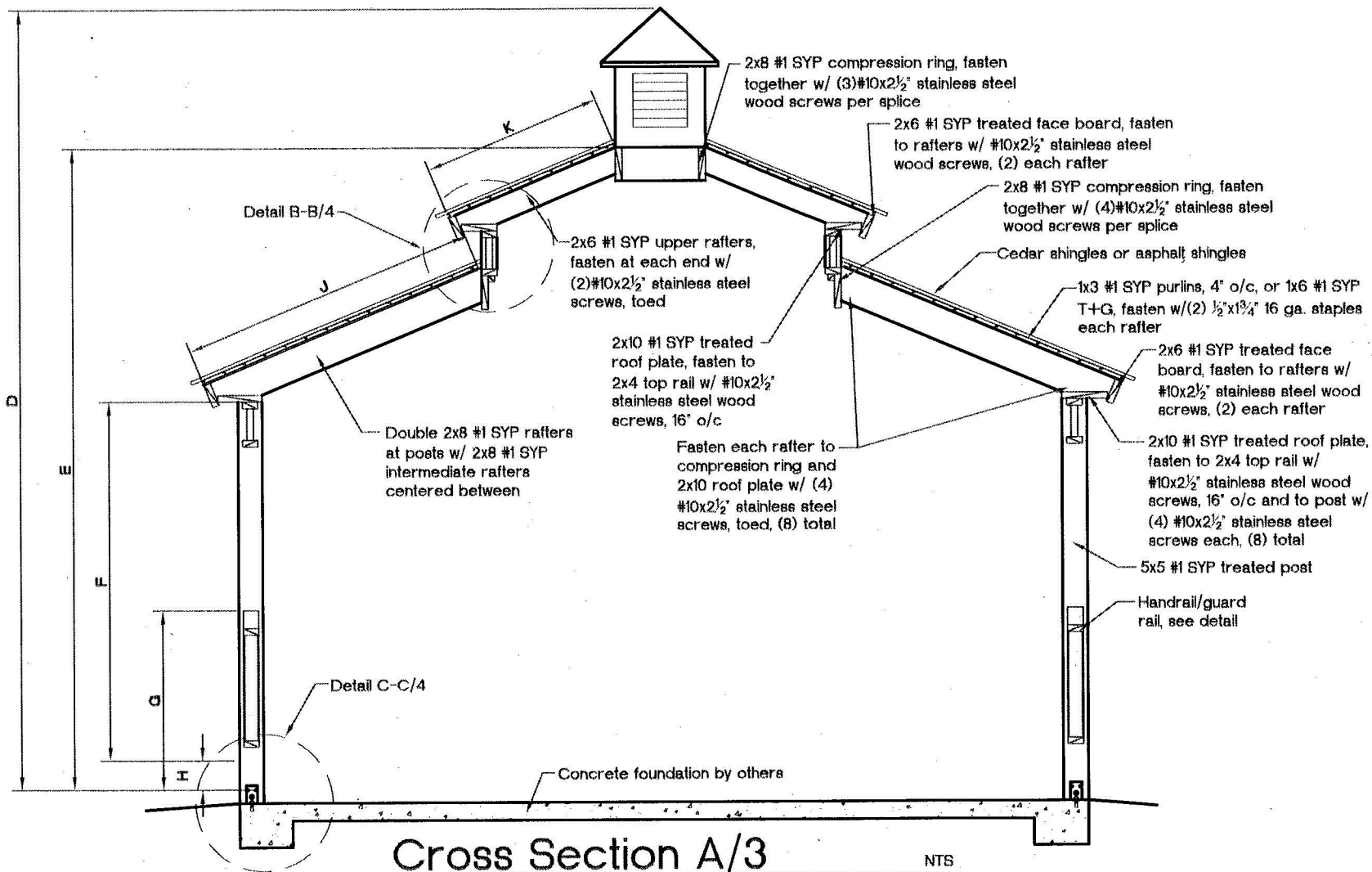

Cross Section A/3

(With out floor)

NTS

DRAWING TITLE:

PROJECT:

DATE	BY
DATE	BY
DATE	BY

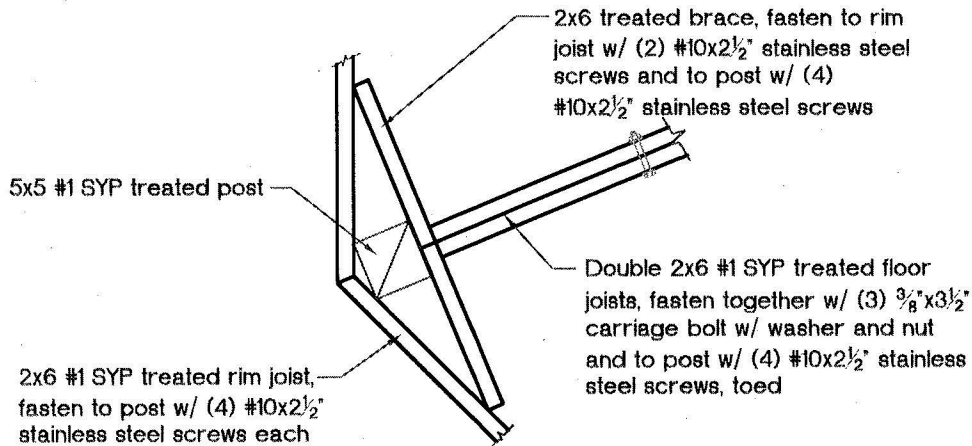

Detail A-A/4

Scale 1" = 1'-0"

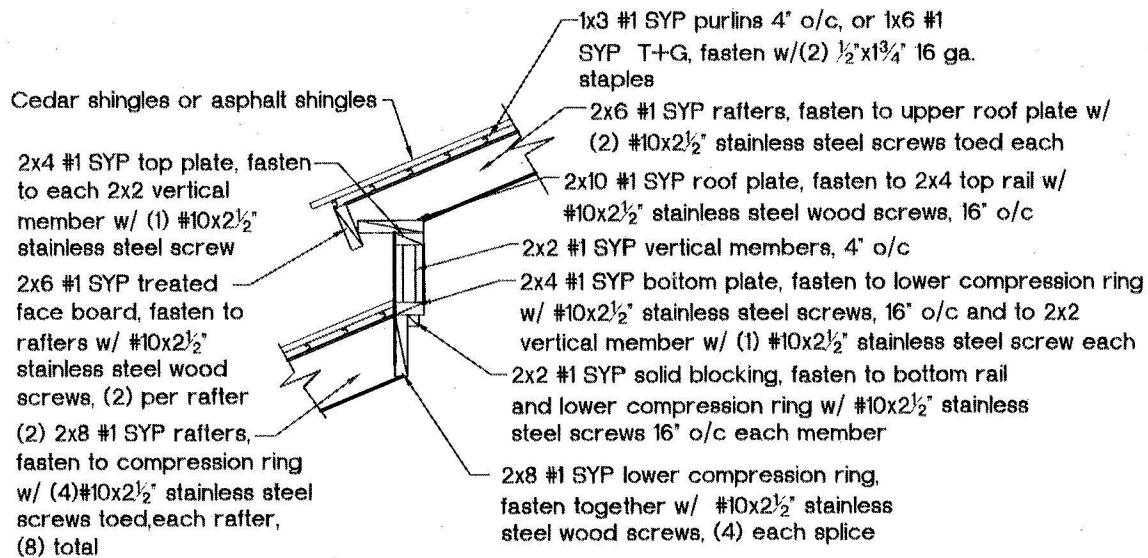

Detail B-B/4

Scale 3/4" = 1'-0"

DRAWING TITLE:

PROJECT:

DESIGNED	DATE	BY
DRAWN		
CHECKED		
SCALE		

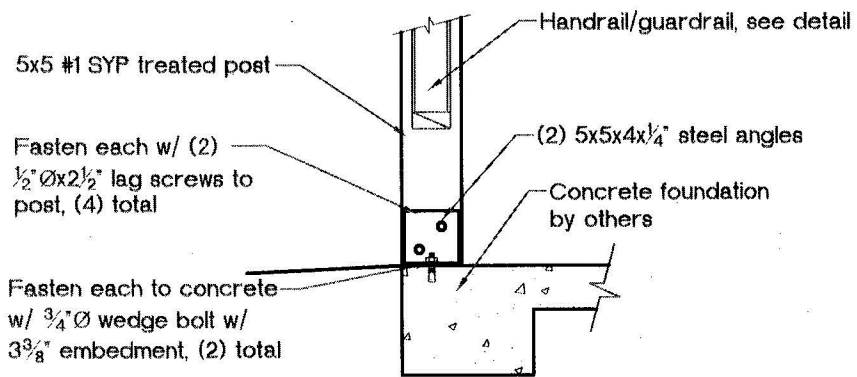

Detail C-C/4

(Wood with out floor)

Scale 1" = 1'-0"

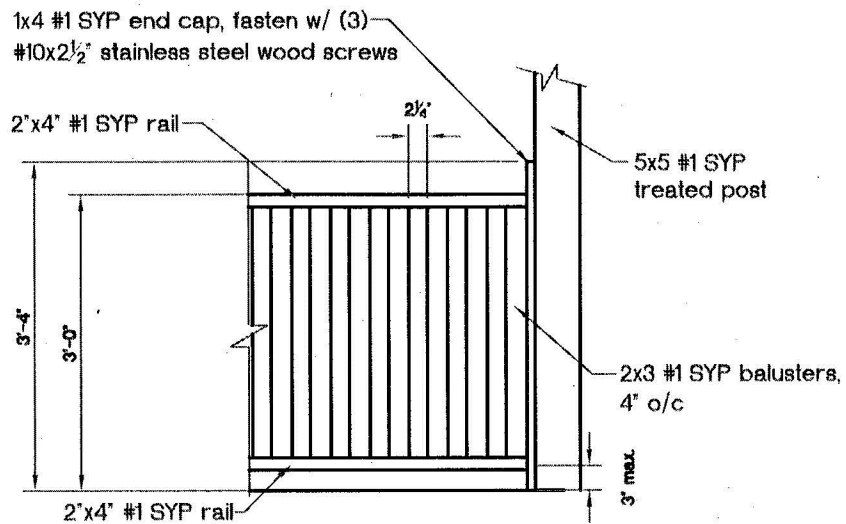

Railing Detail

Scale $\frac{3}{4}$ " = 1'-0"

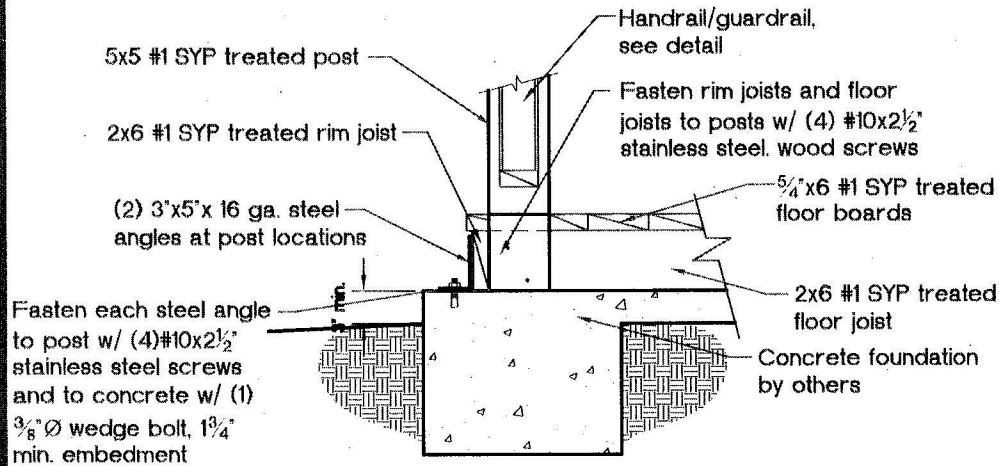

Detail C-C/4

(With floor)

Scale 1" = 1'-0"

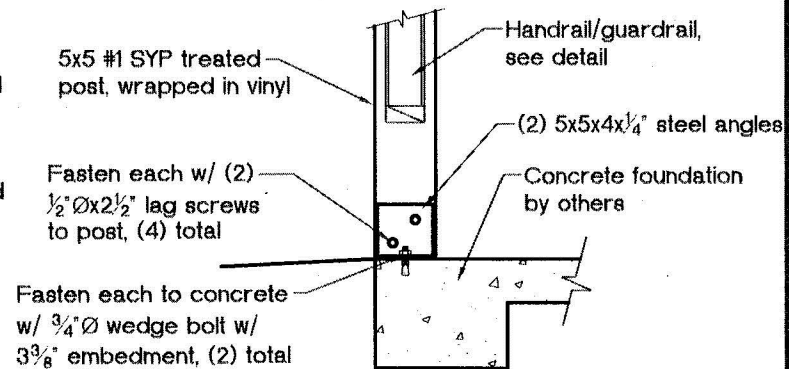

Detail C-C/4

(Vinyl with out floor)

Scale 1" = 1'-0"

DRAWING TITLE:		
PROJECT:		
DATE:	BY:	CHK:

DRAFT AIA® Document A104™ - 2017

Standard Abbreviated Form of Agreement Between Owner and Contractor

AGREEMENT made as of the « » day of « » in the year «2018 »

(In words, indicate day, month and year.)

BETWEEN the Owner:

(Name, legal status, address and other information)

Hull Redevelopment Authority «-» «-»

253 Atlantic Avenue «-»

Hull, MA 02045 «-»

« »

and the Contractor:

(Name, legal status, address and other information)

« » « »

« »

« »

« »

for the following Project:

(Name, location and detailed description)

Nantasket Gazebo Project «-»

Phase II Gazebo Construction «-»

at Nantasket Beach, Hull, Massachusetts «-»

The Architect/Owner's Consultant:

(Name, legal status, address and other information)

« » « »

« »

« »

« »

The Owner and Contractor agree as follows.

ADDITIONS AND DELETIONS: The author of this document has added information needed for its completion. The author may also have revised the text of the original AIA standard form: An *Additions and Deletions Report* that notes added information as well as revisions to the standard form text is available from the author and should be reviewed.

This document has important legal consequences. Consultation with an attorney is encouraged with respect to its completion or modification.

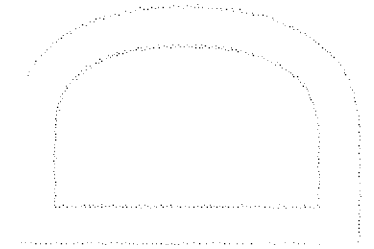
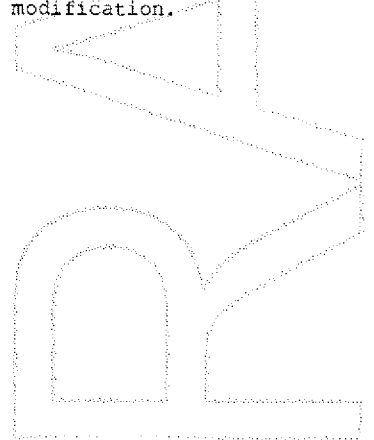

ELECTRONIC COPYING of any portion of this AIA® Document to another electronic file is prohibited and constitutes a violation of copyright laws as set forth in the footer of this document.

TABLE OF ARTICLES

- 1 THE WORK OF THIS CONTRACT
- 2 DATE OF COMMENCEMENT AND SUBSTANTIAL COMPLETION
- 3 CONTRACT SUM
- 4 PAYMENT
- 5 DISPUTE RESOLUTION
- 6 ENUMERATION OF CONTRACT DOCUMENTS
- 7 GENERAL PROVISIONS
- 8 OWNER
- 9 CONTRACTOR
- 10 ARCHITECT
- 11 SUBCONTRACTORS
- 12 CONSTRUCTION BY OWNER OR BY SEPARATE CONTRACTORS
- 13 CHANGES IN THE WORK
- 14 TIME
- 15 PAYMENTS AND COMPLETION
- 16 PROTECTION OF PERSONS AND PROPERTY
- 17 INSURANCE AND BONDS
- 18 CORRECTION OF WORK
- 19 MISCELLANEOUS PROVISIONS
- 20 TERMINATION OF THE CONTRACT
- 21 CLAIMS AND DISPUTES

EXHIBIT A DETERMINATION OF THE COST OF THE WORK

ARTICLE 1 THE WORK OF THIS CONTRACT

§ 1.1 The Contractor shall execute the Work described in the Contract Documents, which are further described in Article 6. except as specifically indicated in the Contract Documents to be the responsibility of others.

§ 1.2 The Contractor represents that it is familiar with the construction of the nature of the Project. The Contractor will provide, within the Contract Sum, the supervision and all other necessary General Conditions in order to facilitate the completion of construction.

§ 1.3 The Contractor shall use its best efforts to assure that all labor employed by the Contractor and by any Subcontractor of any tier performing work on the Project shall cooperate and work in harmony with all Subcontractors

and suppliers performing the work on the Project, no matter by whom employed, in furtherance of the Owner's Interests.

§ 1.4 In general, the Specifications may describe types and qualities of materials, equipment and other items of the Work and methods of installation which cannot be easily shown, or shown in detail, on the Plans. It is not intended to mention every item of Work in the Specifications which can be adequately shown on the Plans or to show on the Plans all items of the Work described or required by the Specifications even if they are of such nature that they could have been shown thereon. All materials, labor, equipment, machinery, services, supplies, plants, tools, scaffolding, transportation, superintendence and other items of Work which are described or will be shown on the Plans or in the Specifications or are reasonably inferable therefrom as being necessary to produce a finished job shall be provided by the Contractor whether or not such items or Work are expressly covered in the Plans and/or Specifications. The contractor warrants to the Owner that all work will be of good quality and workmanship, free from all faults and defects for a period of 12 months from the final completion of the work.

§ 1.5. The Contractor accepts the relationship of trust and confidence established by this Agreement and covenants with the Owner to cooperate with the Architect and exercise the Contractor's skill and judgment in furthering the interests of the Owner; to furnish efficient business administration and supervision; to furnish at all times an adequate supply of workers and materials; and to perform the Work in an expeditious and economical manner consistent with the Owner's interests. The Owner agrees to furnish and approve, in a timely manner, information required by the Contractor and to make payments to the Contractor in accordance with the requirements of the Contract Documents. Furthermore, all phases of construction will be performed in a workmanlike manner and abide by all state and local codes.

ARTICLE 2 DATE OF COMMENCEMENT AND SUBSTANTIAL COMPLETION

§ 2.1 The date of commencement of the Work shall be:

(Check one of the following boxes.)

- The date of this Agreement.
- A date set forth in a notice to proceed issued by the Owner.
- Established as follows:
(Insert a date or a means to determine the date of commencement of the Work.)

If a date of commencement of the Work is not selected, then the date of commencement shall be the date of this Agreement.

§ 2.2 The Contract Time shall be measured from the date of commencement.

§ 2.3 Substantial Completion

§ 2.3.1 Subject to adjustments of the Contract Time as provided in the Contract Documents, the Contractor shall achieve Substantial Completion of the entire Work:

(Check the appropriate box and complete the necessary information.)

- Not later than () calendar days from the date of commencement of the Work.
- By the following date:

§ 2.3.2 Subject to adjustments of the Contract Time as provided in the Contract Documents, if portions of the Work are to be completed prior to Substantial Completion of the entire Work, the Contractor shall achieve Substantial Completion of such portions by the following dates:

Portion of Work

Substantial Completion Date

§ 2.3.3 If the Contractor fails to achieve Substantial Completion as provided in this Section 2.3, liquidated damages, if any, shall be assessed as set forth in Section 3.53.

ARTICLE 3 CONTRACT SUM

§ 3.1 The Owner shall pay the Contractor the Contract Sum in current funds for the Contractor's performance of the Contract. The Contract Sum shall be one of the following:
(Check the appropriate box.)

- [~~« X »~~] Stipulated Sum, in accordance with Section 3.2 below
- [~~« »~~] Cost of the Work plus the Contractor's Fee, in accordance with Section 3.3 below
- [~~« »~~] Cost of the Work plus the Contractor's Fee with a Guaranteed Maximum Price, in accordance with Section 3.4 below

(Based on the selection above, complete Section 3.2, 3.3 or 3.4 below.)

§ 3.2 The Stipulated Sum shall be ~~« »~~ (\$ ~~« »~~), subject to additions and deductions as provided in the Contract Documents.

§ 3.2.1 The Stipulated Sum is based upon the following alternates, if any, which are described in the Contract Documents and are hereby accepted by the Owner:
(State the numbers or other identification of accepted alternates. If the bidding or proposal documents permit the Owner to accept other alternates subsequent to the execution of this Agreement, attach a schedule of such other alternates showing the amount for each and the date when that amount expires.)

~~« »~~

§ 3.2.2 Unit prices, if any:
(Identify the item and state the unit price and the quantity limitations, if any, to which the unit price will be applicable.)

Item	Units and Limitations	Price per Unit (\$0.00)
------	-----------------------	-------------------------

§ 3.2.3 Allowances, if any, included in the stipulated sum:
(Identify each allowance.)

Item	Price
------	-------

~~§ 3.3 Cost of the Work Plus Contractor's Fee~~

~~§ 3.3.1 The Cost of the Work is as defined in Exhibit A, Determination of the Cost of the Work.~~

~~§ 3.3.2 The Contractor's Fee:~~

~~(State a lump sum, percentage of Cost of the Work or other provision for determining the Contractor's Fee and the method of adjustment to the Fee for changes in the Work.)~~

~~« »~~

~~§ 3.4 Cost of the Work Plus Contractor's Fee With a Guaranteed Maximum Price~~

~~§ 3.4.1 The Cost of the Work is as defined in Exhibit A, Determination of the Cost of the Work.~~

~~§ 3.4.2 The Contractor's Fee:~~

~~(State a lump sum, percentage of Cost of the Work or other provision for determining the Contractor's Fee and the method of adjustment to the Fee for changes in the Work.)~~

~~« »~~

§ 3.4.3 Guaranteed Maximum Price

§ 3.4.3.1 The sum of the Cost of the Work and the Contractor's Fee is guaranteed by the Contractor not to exceed ~~« »~~ (\$ ~~« »~~), subject to additions and deductions by changes in the Work as provided in the Contract Documents. This maximum sum is referred to in the Contract Documents as the Guaranteed Maximum Price. Costs which would cause the Guaranteed Maximum Price to be exceeded shall be paid by the Contractor without reimbursement by the Owner. *(Insert specific provisions if the Contractor is to participate in any savings.)*

~~« »~~

§ 3.4.3.2 The Guaranteed Maximum Price is based on the following alternates, if any, which are described in the Contract Documents and are hereby accepted by the Owner:
(State the numbers or other identification of accepted alternates. If the bidding or proposal documents permit the Owner to accept other alternates subsequent to the execution of this Agreement, attach a schedule of such other alternates showing the amount for each and the date when that amount expires.)

~~« »~~

§ 3.4.3.3 Unit Prices, if any:

(Identify the item and state the unit price and the quantity limitations, if any, to which the unit price will be applicable.)

Item	Units and Limitations	Price per Unit (\$0.00)

§ 3.4.3.4 Allowances, if any, included in the Guaranteed Maximum Price:

(Identify each allowance.)

Item	Price

§ 3.4.3.5 Assumptions, if any, on which the Guaranteed Maximum Price is based:

~~« »~~

§ 3.4.3.6 To the extent that the Contract Documents are anticipated to require further development, the Guaranteed Maximum Price includes the costs attributable to such further development consistent with the Contract Documents and reasonably inferable therefrom. Such further development does not include changes in scope, systems, kinds and quality of materials, finishes or equipment, all of which, if required, shall be incorporated by Change Order.

§ 3.4.3.7 The Owner shall authorize preparation of revisions to the Contract Documents that incorporate the agreed-upon assumptions contained in Section 3.4.3.5. The Owner shall promptly furnish such revised Contract Documents to the Contractor. The Contractor shall notify the Owner and Architect of any inconsistencies between the agreed-upon assumptions contained in Section 3.4.3.5 and the revised Contract Documents.

§ 3.5.3 Liquidated damages, if any:

(Insert terms and conditions for liquidated damages, if any.)

~~« »~~

ARTICLE 4 PAYMENT

§ 4.1 Progress Payments

§ 4.1.1 Based upon Applications for Payment submitted to the Architect and the Owner by the Contractor and Certificates for Payment issued by the Architect and the Owner, the Owner shall make progress payments on account of the Contract Sum to the Contractor as provided below and elsewhere in the Contract Documents.

§ 4.1.2 The period covered by each Application for Payment shall be one calendar month ending on the last day of the month, or as follows:

« »

§ 4.1.3 Provided that an Application for Payment is received by the Architect and the Owner not later than the ~~«30th»~~ day of a month, the Owner shall make payment of the certified amount to the Contractor not later than the ~~«30th»~~ day of the ~~«next»~~ month. If an Application for Payment is received by the Architect and the Owner after the date fixed above, payment shall be made by the Owner not later than ~~«thirty»~~ (~~«30»~~) days after the Architect and the Owner receives the Application for Payment.

(Federal, state or local laws may require payment within a certain period of time.)

§ 4.1.4 For each progress payment made prior to Substantial Completion of the Work, the Owner may withhold retainage from the payment otherwise due as follows:

(Insert a percentage or amount to be withheld as retainage from each Application for Payment and any terms for reduction of retainage during the course of the Work. The amount of retainage may be limited by governing law.)

« »10%

§ 4.1.5 Payments due and unpaid under the Contract shall bear interest from the date payment is due at the rate stated below, or in the absence thereof, at the legal rate prevailing from time to time at the place where the Project is located.

(Insert rate of interest agreed upon, if any.)

« » % « »

§ 4.2 Final Payment

§ 4.2.1 Final payment, constituting the entire unpaid balance of the Contract Sum, shall be made by the Owner to the Contractor when

- .1 the Contractor has fully performed the Contract except for the Contractor's responsibility to correct Work as provided in Section 18.2, and to satisfy other requirements, if any, which extend beyond final payment; and
- .2 ~~the Contractor has submitted a final accounting for the Cost of the Work, where payment is on the basis of the Cost of the Work with or without a Guaranteed Maximum Price; and~~
- .32 a final Certificate for Payment has been issued by the Architect in accordance with Section 15.7.1.

§ 4.2.2 The Owner's final payment to the Contractor shall be made no later than 30 days after the issuance of the Architect's and the Owner's final Certificate for Payment, or as follows:

« »

ARTICLE 5 DISPUTE RESOLUTION

§ 5.1 Binding Dispute Resolution

For any claim subject to, but not resolved by, mediation pursuant to Section 21.5, the method of binding dispute resolution shall be as follows:

(Check the appropriate box.)

- Arbitration pursuant to Section 21.6 of this Agreement
- Litigation in a court of competent jurisdiction
- Other *(Specify)*

« » Arbitration or litigation at the Owner's sole option.

If the Owner and Contractor do not select a method of binding dispute resolution, or do not subsequently agree in writing to a binding dispute resolution method other than litigation, claims will be resolved in a court of competent jurisdiction.

ARTICLE 6 ENUMERATION OF CONTRACT DOCUMENTS

§ 6.1 The Contract Documents are defined in Article 7 and, except for Modifications issued after execution of this Agreement, are enumerated in the sections below.

§ 6.1.1 The Agreement is this executed AIA Document A104™-2017, Standard Abbreviated Form of Agreement Between Owner and Contractor, as modified by the parties.

§ 6.1.2 AIA Document E203™-2013, Building Information Modeling and Digital Data Exhibit, dated as indicated below:

(Insert the date of the E203-2013 incorporated into this Agreement.)

« »

§ 6.1.3 The Supplementary and other Conditions of the Contract:

Document	Title	Date	Pages
<u>Supplementary General Conditions</u>			<u>1-5</u>

§ 6.1.4 The Specifications:

(Either list the Specifications here or refer to an exhibit attached to this Agreement.)

« » Attachments 1 and 2

Section	Title	Date	Pages

§ 6.1.5 The Drawings:

(Either list the Drawings here or refer to an exhibit attached to this Agreement.)

Attachments 1 and 2 « »

Number	Title	Date

§ 6.1.6 The Addenda, if any:

Number	Date	Pages

Portions of Addenda relating to bidding or proposal requirements are not part of the Contract Documents unless the bidding or proposal requirements are enumerated in this Article 6.

§ 6.1.7 Additional documents, if any, forming part of the Contract Documents:

.1 Other Exhibits:

(Check all boxes that apply.)

Exhibit A, Determination of the Cost of the Work.

AIA Document E204™-2017, Sustainable Projects Exhibit, dated as indicated below:
(Insert the date of the E204-2017 incorporated into this Agreement.)

« »

The Sustainability Plan:

Title	Date	Pages
-------	------	-------

[« »] Supplementary and other Conditions of the Contract:

Document	Title	Date	Pages
----------	-------	------	-------

- .2 Other documents, if any, listed below:
(List here any additional documents that are intended to form part of the Contract Documents.)

«→The Invitation for Bid and attachments thereto.

ARTICLE 7 GENERAL PROVISIONS

§ 7.1 The Contract Documents

The Contract Documents are enumerated in Article 6 and consist of this Agreement (including, if applicable, Supplementary and other Conditions of the Contract), Drawings, Specifications, Addenda issued prior to the execution of this Agreement, other documents listed in this Agreement, and Modifications issued after execution of this Agreement. A Modification is (1) a written amendment to the Contract signed by both parties, (2) a Change Order, (3) a Construction Change Directive, or (4) a written order for a minor change in the Work issued by the Architect. The intent of the Contract Documents is to include all items necessary for the proper execution and completion of the Work by the Contractor. The Contract Documents are complementary, and what is required by one shall be as binding as if required by all; performance by the Contractor shall be required to the extent consistent with the Contract Documents and reasonably inferable from them as being necessary to produce the indicated results.

§ 7.2 The Contract

The Contract Documents form the Contract for Construction. The Contract represents the entire and integrated agreement between the parties hereto and supersedes prior negotiations, representations, or agreements, either written or oral. The Contract may be amended or modified only by a Modification. The Contract Documents shall not be construed to create a contractual relationship of any kind between any persons or entities other than the Owner and the Contractor.

§ 7.3 The Work

The term “Work” means the construction and services required by the Contract Documents, whether completed or partially completed, and includes all other labor, materials, equipment, and services provided or to be provided by the Contractor to fulfill the Contractor’s obligations. The Work may constitute the whole or a part of the Project.

§ 7.4 Instruments of Service

Instruments of Service are representations, in any medium of expression now known or later developed, of the tangible and intangible creative work performed by the Architect and the Architect’s consultants under their respective professional services agreements. Instruments of Service may include, without limitation, studies, surveys, models, sketches, drawings, specifications, and other similar materials.

§ 7.5 Ownership and use of Drawings, Specifications and Other Instruments of Service

§ 7.5.1 The Architect and the Architect’s consultants shall be deemed the authors and owners of their respective Instruments of Service, including the Drawings and Specifications, and will retain all common law, statutory and other reserved rights in their Instruments of Service, including copyrights. The Contractor, Subcontractors, Sub-subcontractors, and suppliers shall not own or claim a copyright in the Instruments of Service. Submittal or distribution to meet official regulatory requirements or for other purposes in connection with the Project is not to be construed as publication in derogation of the Architect’s or Architect’s consultants’ reserved rights.

§ 7.5.2 The Contractor, Subcontractors, Sub-subcontractors and suppliers are authorized to use and reproduce the Instruments of Service provided to them, subject to the protocols established pursuant to Sections 7.6 and 7.7, solely and exclusively for execution of the Work. All copies made under this authorization shall bear the copyright notice, if any, shown on the Instruments of Service. The Contractor, Subcontractors, Sub-subcontractors, and suppliers may not use the Instruments of Service on other projects or for additions to this Project outside the scope of the Work without the specific written consent of the Owner, Architect and the Architect’s consultants.

§ 7.6 Digital Data Use and Transmission

The parties shall agree upon protocols governing the transmission and use of Instruments of Service or any other information or documentation in digital form. The parties will use AIA Document E203™-2013, Building Information Modeling and Digital Data Exhibit, to establish the protocols for the development, use, transmission, and exchange of digital data.

§ 7.7 Building Information Models Use and Reliance

Any use of, or reliance on, all or a portion of a building information model without agreement to protocols governing the use of, and reliance on, the information contained in the model and without having those protocols set forth in AIA Document E203™-2013, Building Information Modeling and Digital Data Exhibit, and the requisite AIA Document G202™-2013, Project Building Information Modeling Protocol Form, shall be at the using or relying party's sole risk and without liability to the other party and its contractors or consultants, the authors of, or contributors to, the building information model, and each of their agents and employees.

§ 7.8 Severability

The invalidity of any provision of the Contract Documents shall not invalidate the Contract or its remaining provisions. If it is determined that any provision of the Contract Documents violates any law, or is otherwise invalid or unenforceable, then that provision shall be revised to the extent necessary to make that provision legal and enforceable. In such case the Contract Documents shall be construed, to the fullest extent permitted by law, to give effect to the parties' intentions and purposes in executing the Contract.

§ 7.9 Notice

§ 7.9.1 Except as otherwise provided in Section 7.9.2, where the Contract Documents require one party to notify or give notice to the other party, such notice shall be provided in writing to the designated representative of the party to whom the notice is addressed and shall be deemed to have been duly served if delivered in person, by mail, by courier, or by electronic transmission in accordance with AIA Document E203™-2013, Building Information Modeling and Digital Data Exhibit, if completed, or as otherwise set forth below:

(If other than in accordance with AIA Document E203-2013, insert requirements for delivering Notice in electronic format such as name, title and email address of the recipient and whether and how the system will be required to generate a read receipt for the transmission.)

« »

§ 7.9.2 Notice of Claims shall be provided in writing and shall be deemed to have been duly served only if delivered to the designated representative of the party to whom the notice is addressed by certified or registered mail, or by courier providing proof of delivery.

§ 7.10 Relationship of the Parties

Where the Contract is based on the Cost of the Work plus the Contractor's Fee, with or without a Guaranteed Maximum Price, the Contractor accepts the relationship of trust and confidence established by this Agreement and covenants with the Owner to cooperate with the Architect and exercise the Contractor's skill and judgment in furthering the interests of the Owner; to furnish efficient business administration and supervision; to furnish at all times an adequate supply of workers and materials; and to perform the Work in an expeditious and economical manner consistent with the Owner's interests. The Owner agrees to furnish and approve, in a timely manner, information required by the Contractor and to make payments to the Contractor in accordance with the requirements of the Contract Documents.

ARTICLE 8 OWNER

§ 8.1 Information and Services Required of the Owner

§ 8.1.1 Prior to commencement of the Work, at the written request by the Contractor, the Owner shall furnish to the Contractor reasonable evidence that the Owner has made financial arrangements to fulfill the Owner's obligations under the Contract. The Contractor shall have no obligation to commence the Work until the Owner provides such evidence. If commencement of the Work is delayed under this Section 8.1.1, the Contract Time shall be extended appropriately.

§ 8.1.2 The Owner shall furnish all necessary surveys and a legal description of the site.

§ 8.1.3 The Contractor shall be entitled to rely on the accuracy of information furnished by the Owner but shall exercise proper precautions relating to the safe performance of the Work.

§ 8.1.4 Except for permits and fees that are the responsibility of the Contractor under the Contract Documents, including those required under Section 9.6.1, the Owner shall secure and pay for other necessary approvals, easements, assessments, and charges required for the construction, use, or occupancy of permanent structures or for permanent changes in existing facilities.

§ 8.2 Owner's Right to Stop the Work

If the Contractor fails to correct Work which is not in accordance with the requirements of the Contract Documents, or repeatedly fails to carry out the Work in accordance with the Contract Documents, the Owner may issue a written order to the Contractor to stop the Work, or any portion thereof, until the cause for such order is eliminated; however, the right of the Owner to stop the Work shall not give rise to a duty on the part of the Owner to exercise this right for the benefit of the Contractor or any other person or entity.

§ 8.3 Owner's Right to Carry Out the Work

If the Contractor defaults or neglects to carry out the Work in accordance with the Contract Documents, and fails within a ten-day period after receipt of notice from the Owner to commence and continue correction of such default or neglect with diligence and promptness, the Owner may, without prejudice to any other remedies the Owner may have, correct such default or neglect. Such action by the Owner and amounts charged to the Contractor are both subject to prior approval of the Architect and the Architect may, pursuant to Section 15.4.3, withhold or nullify a Certificate for Payment in whole or in part, to the extent reasonably necessary to reimburse the Owner for the reasonable cost of correcting such deficiencies, including the Owner's expenses and compensation for the Architect's additional services made necessary by such default, neglect, or failure. If the Contractor disagrees with the actions of the Owner or the Architect, or the amounts claimed as costs to the Owner, the Contractor may file a Claim pursuant to Article 21.

§ 8.4 The Owner shall designate in writing a representative who shall have express authority to bind the Owner with respect to all matters requiring the Owner's approval or authorization

ARTICLE 9 CONTRACTOR

§ 9.1 Review of Contract Documents and Field Conditions by Contractor

§ 9.1.1 Execution of the Contract by the Contractor is a representation that the Contractor has visited the site, become generally familiar with local conditions under which the Work is to be performed and correlated personal observations with requirements of the Contract Documents.

§ 9.1.2 Because the Contract Documents are complementary, the Contractor shall, before starting each portion of the Work, carefully study and compare the various Contract Documents relative to that portion of the Work, as well as the information furnished by the Owner pursuant to Section 8.1.2, shall take field measurements of any existing conditions related to that portion of the Work and shall observe any conditions at the site affecting it. These obligations are for the purpose of facilitating coordination and construction by the Contractor and are not for the purpose of discovering errors, omissions, or inconsistencies in the Contract Documents; however, the Contractor shall promptly report to the Architect any errors, inconsistencies, or omissions discovered by or made known to the Contractor as a request for information in such form as the Architect may require. It is recognized that the Contractor's review is made in the Contractor's capacity as a contractor and not as a licensed design professional unless otherwise specifically provided in the Contract Documents.

§ 9.1.3 The Contractor is not required to ascertain that the Contract Documents are in accordance with applicable laws, statutes, ordinances, codes, rules and regulations, or lawful orders of public authorities, but the Contractor shall promptly report to the Architect any nonconformity discovered by or made known to the Contractor as a request for information in such form as the Architect may require.

§ 9.2 Supervision and Construction Procedures

§ 9.2.1 The Contractor shall supervise and direct the Work, using the Contractor's best skill and attention. The Contractor shall be solely responsible for and have control over construction means, methods, techniques, sequences, and procedures, and for coordinating all portions of the Work under the Contract, unless the Contract Documents give other specific instructions concerning these matters.

§ 9.2.2 The Contractor shall be responsible to the Owner for acts and omissions of the Contractor's employees, Subcontractors and their agents and employees, and other persons or entities performing portions of the Work for or on behalf of the Contractor or any of its Subcontractors.

§ 9.3 Labor and Materials

§ 9.3.1 Unless otherwise provided in the Contract Documents, the Contractor shall provide and pay for labor, materials, equipment, tools, construction equipment and machinery, water, heat, utilities, transportation, and other facilities and services necessary for proper execution and completion of the Work whether temporary or permanent and whether or not incorporated or to be incorporated in the Work.

§ 9.3.2 The Contractor shall enforce strict discipline and good order among the Contractor's employees and other persons carrying out the Work. The Contractor shall not permit employment of unfit persons or persons not skilled in tasks assigned to them. The Contractor agrees to assign the same on-site supervisory personnel to the Project throughout the term of the Work unless otherwise agreed by the Owner or unless such person(s) is/are no longer employed by the Contractor, in which case the replacement on-site supervisory personnel must be approved by the Owner, which approval shall not be unreasonably withheld.

§ 9.3.3 The Contractor may make a substitution only with the consent of the Owner, after evaluation by the Architect and in accordance with a Modification.

§ 9.4 Warranty

The Contractor warrants to the Owner and Architect that materials and equipment furnished under the Contract will be of good quality and new unless the Contract Documents require or permit otherwise. The Contractor further warrants that the Work will conform to the requirements of the Contract Documents and will be free from defects, except for those inherent in the quality of the Work the Contract Documents require or permit. Work, materials, or equipment not conforming to these requirements may be considered defective. The Contractor's warranty excludes remedy for damage or defect caused by abuse, alterations to the Work not executed by the Contractor, improper or insufficient maintenance, improper operation or normal wear and tear under normal usage. All other warranties required by the Contract Documents shall be issued in the name of the Owner, or shall be transferable to the Owner, and shall commence in accordance with Section 15.6.3. If required by the Architect and/or the Owner, the Contractor shall furnish satisfactory evidence as to the kind and quality of materials and equipment.

§ 9.5 Taxes

The Contractor shall pay sales, consumer, use, and other similar taxes that are legally enacted when bids are received or negotiations concluded, whether or not yet effective or merely scheduled to go into effect.

§ 9.6 Permits, Fees, Notices, and Compliance with Laws

§ 9.6.1 Unless otherwise provided in the Contract Documents, the Contractor shall secure and pay for ~~the building permit as well as other permits,~~ fees, licenses, and inspections by government agencies necessary for proper execution and completion of the Work that are customarily secured after execution of the Contract and legally required at the time bids are received or negotiations concluded.

§ 9.6.2 The Contractor shall comply with and give notices required by applicable laws, statutes, ordinances, codes, rules and regulations, and lawful orders of public authorities applicable to performance of the Work. If the Contractor performs Work knowing it to be contrary to applicable laws, statutes, ordinances, codes, rules and regulations, or lawful orders of public authorities, the Contractor shall assume appropriate responsibility for such Work and shall bear the costs attributable to correction.

§ 9.7 Allowances

The Contractor shall include in the Contract Sum all allowances stated in the Contract Documents. The Owner shall select materials and equipment under allowances with reasonable promptness. Allowance amounts shall include the costs to the Contractor of materials and equipment delivered at the site and all required taxes, less applicable trade discounts. Contractor's costs for unloading and handling at the site, labor, installation, overhead, profit, and other expenses contemplated for stated allowance amounts shall be included in the Contract Sum but not in the allowance.

§ 9.8 Contractor's Construction Schedules

§ 9.8.1 The Contractor, promptly after being awarded the Contract, shall submit for the Owner's and Architect's information a Contractor's construction schedule for the Work. The schedule shall not exceed time limits current under the Contract Documents, shall be revised at appropriate intervals as required by the conditions of the Work and Project, shall be related to the entire Project to the extent required by the Contract Documents, and shall provide for expeditious and practicable execution of the Work.

§ 9.8.2 The Contractor shall perform the Work in general accordance with the most recent schedule submitted to the Owner and Architect.

§ 9.9 Submittals

§ 9.9.1 The Contractor shall review for compliance with the Contract Documents and submit to the Architect Shop Drawings, Product Data, Samples, and similar submittals required by the Contract Documents in coordination with the Contractor's construction schedule and in such sequence as to allow the Architect reasonable time for review. By submitting Shop Drawings, Product Data, Samples, and similar submittals, the Contractor represents to the Owner and Architect that the Contractor has (1) reviewed and approved them; (2) determined and verified materials, field measurements, and field construction criteria related thereto, or will do so; and (3) checked and coordinated the information contained within such submittals with the requirements of the Work and of the Contract Documents. The Work shall be in accordance with approved submittals. The Contractor shall perform no portion of the Work for which the Contract Documents require submittal and review of Shop Drawings, Product Data, Samples or other submittals until the respective submittal has been approved by the Architect and/or the Owner.

§ 9.9.2 Shop Drawings, Product Data, Samples and similar submittals are not Contract Documents.

§ 9.9.3 The Contractor shall not be required to provide professional services that constitute the practice of architecture or engineering unless such services are specifically required by the Contract Documents or unless the Contractor needs to provide such services in order to carry out the Contractor's own responsibilities. If professional design services or certifications by a design professional are specifically required, the Owner and the Architect will specify the performance and design criteria that such services must satisfy. The Contractor shall cause such services or certifications to be provided by an appropriately licensed design professional. If no criteria are specified, the design shall comply with applicable codes and ordinances. Each Party shall be entitled to rely upon the information provided by the other Party. The Architect will review and approve or take other appropriate action on submittals for the limited purpose of checking for conformance with information provided and the design concept expressed in the Contract Documents. The Architect's review of Shop Drawings, Product Data, Samples, and similar submittals shall be for the limited purpose of checking for conformance with information given and the design concept expressed in the Contract Documents. In performing such review, the Architect will approve, or take other appropriate action upon, the Contractor's Shop Drawings, Product Data, Samples, and similar submittals.

§ 9.10 Use of Site

The Contractor shall confine operations at the site to areas permitted by applicable laws, statutes, ordinances, codes, rules and regulations, lawful orders of public authorities, and the Contract Documents and shall not unreasonably encumber the site with materials or equipment.

§ 9.11 Cutting and Patching

The Contractor shall be responsible for cutting, fitting, or patching required to complete the Work or to make its parts fit together properly. All areas requiring cutting, fitting and patching shall be restored to the condition existing prior to the cutting, fitting and patching, unless otherwise required by the Contract Documents.

§ 9.12 Cleaning Up

The Contractor shall keep the premises and surrounding area free from accumulation of waste materials and rubbish caused by operations under the Contract. At completion of the Work, the Contractor shall remove waste materials, rubbish, the Contractor's tools, construction equipment, machinery, and surplus material from and about the Project. If the Contractor fails to clean up as provided in the Contract Documents, the Owner may do so and Owner shall be entitled to reimbursement from the Contractor.

§ 9.13 Access to Work

The Contractor shall provide the Owner and Architect with access to the Work in preparation and progress wherever located.

§ 9.14 Royalties, Patents and Copyrights

The Contractor shall pay all royalties and license fees. The Contractor shall defend suits or claims for infringement of copyrights and patent rights and shall hold the Owner and Architect harmless from loss on account thereof, but shall not be responsible for defense or loss when a particular design, process, or product of a particular manufacturer or manufacturers is required by the Contract Documents or where the copyright violations are contained in Drawings, Specifications or other documents prepared by the Owner or Architect. However, if an infringement of a copyright or patent is discovered by, or made known to, the Contractor, the Contractor shall be responsible for the loss unless the information is promptly furnished to the Architect.

§ 9.15 Indemnification

§ 9.15.1 To the fullest extent permitted by law, the Contractor shall indemnify and hold harmless the Owner, Architect, Architect's consultants, and agents and employees of any of them from and against claims, damages, losses and expenses, including but not limited to attorneys' fees, arising out of or resulting from performance of the Work, provided that such claim, damage, loss, or expense is attributable to bodily injury, sickness, disease or death, or to injury to or destruction of tangible property (other than the Work itself), but only to the extent caused by the negligent acts or omissions of the Contractor, a Subcontractor, anyone directly or indirectly employed by them, or anyone for whose acts they may be liable, regardless of whether or not such claim, damage, loss, or expense is caused in part by a party indemnified hereunder. Such obligation shall not be construed to negate, abridge, or reduce other rights or obligations of indemnity which would otherwise exist as to a party or person described in this Section 9.15.1.

§ 9.15.2 In claims against any person or entity indemnified under this Section 9.15 by an employee of the Contractor, a Subcontractor, anyone directly or indirectly employed by them, or anyone for whose acts they may be liable, the indemnification obligation under Section 9.15.1 shall not be limited by a limitation on amount or type of damages, compensation or benefits payable by or for the Contractor or Subcontractor under workers' compensation acts, disability benefit acts or other employee benefit acts.

§ 9.16 The Contractor shall be lawfully licensed, if required in the jurisdiction where the Project is located. The Contractor shall designate in writing a representative who shall have express authority to bind the Contractor with respect to all matters under this Agreement. The Contractor shall perform the Work in accordance with the Contract Documents. The Contractor shall not be relieved of its obligations to perform the Work in accordance with the Contract Documents either by activities or duties of the Architect in the Architect's administration of the Contract, or by tests, inspections or approvals required or performed by persons or entities other than the Contractor.

§ 9.17 The Contractor shall supervise and direct the work, using his best skill and attention. The Contractor shall be solely responsible for all construction means, methods, techniques, sequences and procedures and for coordinating all portions of the work under the Contract.

§ 9.18 Unless otherwise specifically noted, the Contractor shall provide and pay for all labor, materials, equipment, tools, construction equipment and machinery, transportation and other facilities and services necessary for the proper execution and completion of the work.

§ 9.19 The Contractor shall give all notices and comply with all laws, ordinances, rules, regulations, and orders of any public authority bearing on the performance of the Work, and shall notify the Architect and the Owner if the Drawings and Specifications are at variance therewith.

§ 9.20 The Contractor shall be responsible for the acts and omissions of all his employees and all Subcontractors, their agents and employees and all other persons performing any of the Work under a contract with the Contractor.

ARTICLE 10 ARCHITECT

§ 10.1 The Architect will provide administration of the Contract as described in the Contract Documents and will be an Owner's representative during construction, until the date the Architect issues the final Certificate for Payment. The Architect will have authority to act on behalf of the Owner only to the extent provided in the Contract Documents, unless otherwise modified in writing in accordance with other provisions of the Contract. The Architect will be, in the

first instance, the interpreter of the requirements of the Contract Documents. He will make decisions on all claims and disputes between the Owner and the Contractor. All his decisions are subject to arbitration. The Architect will have authority to reject Work which does not conform to the Contract Documents. For the purposes of this Agreement and the Supplementary General Conditions, the duties and responsibilities of the Architect will be performed by the Owner's Consultant identified on p. 1 of this Agreement and any references in this Agreement and the Supplementary General Conditions to the Architect shall mean the Owner's Consultant.

§ 10.2 Duties, responsibilities, and limitations of authority of the Architect as set forth in the Contract Documents shall not be restricted, modified, or extended without written consent of the Owner, Contractor, and Architect. Consent shall not be unreasonably withheld.

§ 10.3 The Architect will visit the site at intervals appropriate to the stage of the construction to become generally familiar with the progress and quality of the portion of the Work completed, and to determine in general, if the Work observed is being performed in a manner indicating that the Work, when fully completed, will be in accordance with the Contract Documents. However, the Architect will not be required to make exhaustive or continuous on-site inspections to check the quality or quantity of the Work. The Architect will not have control over, charge of, or responsibility for the construction means, methods, techniques, sequences, or procedures, or for safety precautions and programs in connection with the Work, since these are solely the Contractor's rights and responsibilities under the Contract Documents except as provided in § 10.1.

§ 10.4 On the basis of the site visits, the Architect will keep the Owner reasonably informed about the progress and quality of the portion of the Work completed, and promptly report to the Owner (1) known deviations from the Contract Documents, (2) known deviations from the most recent construction schedule submitted by the Contractor, and (3) defects and deficiencies observed in the Work. The Architect will not be responsible for the Contractor's failure to perform the Work in accordance with the requirements of the Contract Documents. The Architect will not have control over or charge of and will not be responsible for acts or omissions of the Contractor, Subcontractors, or their agents or employees, or any other persons or entities performing portions of the Work.

§ 10.5 Based on the Architect's and/or the Owner's evaluations of the Work and of the Contractor's Applications for Payment, the Architect and/or the Owner will review and certify the amounts due the Contractor and will issue Certificates for Payment in such amounts. If the Architect and/or the Owner determines that the work or a portion thereof has not been performed in accordance with the terms of the Contract, the Owner may withhold further payment to the Contractor in an amount as may be necessary, in the Architect's and/or the Owner's opinion, to protect the Owner from loss for said non-conforming work until such time as said non-conforming work is brought into compliance with the terms of the Contract.

§ 10.6 The Architect and/or the Owner has authority to reject Work that does not conform to the Contract Documents and to require inspection or testing of the Work.

§ 10.7 The Architect and/or the Owner will review and approve or take other appropriate action upon, the Contractor's submittals such as Shop Drawings, Product Data, and Samples, but only for the limited purpose of checking for conformance with information given and the design concept expressed in the Contract Documents. The Architect's and/or the Owner's review of the Contractor's submittals shall not relieve the Contractor of its obligations under this Agreement.

§ 10.8 The Architect will interpret and decide matters concerning performance under, and requirements of, the Contract Documents on written request of either the Owner or Contractor. The Architect's response to such requests will be made in writing with reasonable promptness. Interpretations and decisions of the Architect will be consistent with the intent of, and reasonably inferable from, the Contract Documents. The Architect will not show partiality to either the Owner or the Contractor. The Architect will make initial decisions on all claims, disputes, and other matters in question between the Owner and Contractor but will not be liable for results of any interpretations or decisions rendered in good faith.

§ 10.9 The Architect's decisions on matters relating to aesthetic effect will be final if consistent with the intent expressed in the Contract Documents.

§ 10.10 The Architect will review and respond to requests for information about the Contract Documents. The Architect's response to such requests will be made in writing within any time limits agreed upon or otherwise with reasonable promptness. If appropriate, the Architect will prepare and issue supplemental drawings and Specifications in response to the requests for information.

ARTICLE 11 SUBCONTRACTORS

§ 11.1 A Subcontractor is a person or entity who has a direct contract with the Contractor to perform a portion of the Work at the site.

§ 11.2 Unless otherwise stated in the Contract Documents, the Contractor, as soon as practicable after award of the Contract, shall notify the Owner and Architect of the Subcontractors or suppliers proposed for each of the principal portions of the Work. The Contractor shall not contract with any Subcontractor or supplier to whom the Owner or Architect has made reasonable written objection within ten days after receipt of the Contractor's list of Subcontractors and suppliers. If the proposed but rejected Subcontractor was reasonably capable of performing the Work, the Contract Sum and Contract Time shall be increased or decreased by the difference, if any, occasioned by such change, and an appropriate Change Order shall be issued before commencement of the substitute Subcontractor's Work. The Contractor shall not be required to contract with anyone to whom the Contractor has made reasonable objection.

§ 11.3 Contracts between the Contractor and Subcontractors shall (1) require each Subcontractor, to the extent of the Work to be performed by the Subcontractor, to be bound to the Contractor by the terms of the Contract Documents, and to assume toward the Contractor all the obligations and responsibilities, including the responsibility for safety of the Subcontractor's Work, which the Contractor, by the Contract Documents, assumes toward the Owner and Architect, and (2) allow the Subcontractor the benefit of all rights, remedies and redress against the Contractor that the Contractor, by these Contract Documents, has against the Owner.

ARTICLE 12 CONSTRUCTION BY OWNER OR BY SEPARATE CONTRACTORS

§ 12.1 The term "Separate Contractor(s)" shall mean other contractors retained by the Owner under separate agreements. The Owner reserves the right to perform construction or operations related to the Project with the Owner's own forces, and with Separate Contractors retained under Conditions of the Contract substantially similar to those of this Contract, including those provisions of the Conditions of the Contract related to insurance and waiver of subrogation.

§ 12.2 The Contractor shall afford the Owner and Separate Contractors reasonable opportunity for introduction and storage of their materials and equipment and performance of their activities, and shall connect and coordinate the Contractor's activities with theirs as required by the Contract Documents.

§ 12.3 The Owner shall be reimbursed by the Contractor for costs incurred by the Owner which are payable to a Separate Contractor because of delays, improperly timed activities, or defective construction of the Contractor. The Owner shall be responsible to the Contractor for costs incurred by the Contractor because of delays, improperly timed activities, damage to the Work, or defective construction of a Separate Contractor.

ARTICLE 13 CHANGES IN THE WORK

§ 13.1 By appropriate Modification, changes in the Work may be accomplished after execution of the Contract. The Owner, without invalidating the Contract, may order changes in the Work within the general scope of the Contract consisting of additions, deletions, or other revisions, with the Contract Sum and Contract Time being adjusted accordingly. Such changes in the Work shall be authorized by written Change Order signed by the Owner, Contractor, and Architect, or by written Construction Change Directive signed by the Owner and Architect. Upon issuance of the Change Order or Construction Change Directive, the Contractor shall proceed promptly with such changes in the Work, unless otherwise provided in the Change Order or Construction Change Directive.

§ 13.2 Adjustments in the Contract Sum and Contract Time resulting from a change in the Work shall be determined by mutual agreement of the parties or, in the case of a Construction Change Directive signed only by the Owner and Architect, by the Contractor's cost of labor, material, equipment, and reasonable overhead and profit, unless the parties agree on another method for determining the cost or credit. Pending final determination of the total cost of a Construction Change Directive, the Contractor may request payment for Work completed pursuant to the Construction Change Directive. The Architect will make an interim determination of the amount of payment due for purposes of

certifying the Contractor's monthly Application for Payment. When the Owner and Contractor agree on adjustments to the Contract Sum and Contract Time arising from a Construction Change Directive, the Architect will prepare a Change Order.

§ 13.3 The Architect will have authority to order minor changes in the Work not involving adjustment in the Contract Sum or extension of the Contract Time and not inconsistent with the intent of the Contract Documents. Such changes shall be effected by written order and shall be binding on the Owner and Contractor. The Contractor shall carry out such written orders promptly. If the Contractor believes that the proposed minor change in the Work will affect the Contract Sum or Contract Time, the Contractor shall notify the Architect and shall not proceed to implement the change in the Work.

§ 13.4 If the Contractor encounters conditions at the site that are (1) subsurface or otherwise concealed physical conditions that differ materially from those indicated in the Contract Documents or (2) unknown physical conditions of an unusual nature, that differ materially from those ordinarily found to exist and generally recognized as inherent in construction activities of the character provided for in the Contract Documents, the Contractor shall promptly provide notice to the Owner and the Architect before conditions are disturbed and in no event later than 21 days after first observance of the conditions. The Architect and Owner will promptly investigate such conditions and, if the Architect and the Owner determine that they differ materially and cause an increase or decrease in the Contractor's cost of, or time required for, performance of any part of the Work, will recommend an equitable adjustment in the Contract Sum or Contract Time, or both. If the Architect and the Owner determine that the conditions at the site are not materially different from those indicated in the Contract Documents and that no change in the terms of the Contract is justified, the Architect and the Owner shall promptly notify the Contractor in writing, stating the reasons. If the Contractor disputes the Architect's and the Owner's determination or recommendation, the Contractor may proceed as provided in Article 21. If concealed or unknown physical conditions are encountered at the site that differ materially from those indicated in the Contract Documents or from those conditions ordinarily found to exist, the Contract Sum and Contract Time shall be equitably adjusted as mutually agreed between the Owner and Contractor, provided that the Contractor provides notice to the Owner and Architect promptly and before conditions are disturbed.

ARTICLE 14 TIME

§ 14.1 Time limits stated in the Contract Documents are of the essence of the Contract. By executing this Agreement the Contractor confirms that the Contract Time is a reasonable period for performing the Work.

§ 14.2 Unless otherwise provided, Contract Time is the period of time, including authorized adjustments, allotted in the Contract Documents for Substantial Completion of the Work.

§ 14.3 The term "day" as used in the Contract Documents shall mean calendar day unless otherwise specifically defined.

§ 14.4 The date of Substantial Completion is the date certified by the Architect in accordance with Section 15.6.3.

§ 14.5 If the Contractor is delayed at any time in the commencement or progress of the Work by (1) changes ordered in the Work; (2) by labor disputes, fire, unusual delay in deliveries, abnormal adverse weather conditions not reasonably anticipatable, unavoidable casualties, or any causes beyond the Contractor's control; or (3) by other causes that the Contractor asserts, and the Architect determines, justify delay, then the Contract Time shall be extended for such reasonable time as the Architect may determine, subject to the provisions of Article 21.

ARTICLE 15 PAYMENTS AND COMPLETION

§ 15.1 Schedule of Values

§ 15.1.1 Where the Contract is based on a Stipulated Sum ~~or the Cost of the Work with a Guaranteed Maximum Price pursuant to Section 3.2 or 3.4~~, the Contractor shall submit a schedule of values to the Architect and the Owner before the first Application for Payment, allocating the entire Stipulated Sum ~~or Guaranteed Maximum Price~~ to the various portions of the Work. The schedule of values shall be prepared in the form, and supported by the data to substantiate its accuracy required by the Architect and the Owner. This schedule of values shall be used as a basis for reviewing the Contractor's Applications for Payment.

~~§ 15.1.2~~ The allocation of the Stipulated Sum or ~~Guaranteed Maximum Price~~ under this Section 15.1 shall not constitute a separate stipulated sum or ~~guaranteed maximum price~~ for each individual line item in the schedule of values.

~~§ 15.2 Control Estimate~~

~~§ 15.2.1~~ Where the Contract Sum is the Cost of the Work, plus the Contractor's Fee without a ~~Guaranteed Maximum Price~~ pursuant to Section 3.3, the Contractor shall prepare and submit to the Owner a Control Estimate within 14 days of executing this Agreement. The Control Estimate shall include the estimated Cost of the Work plus the Contractor's Fee:

~~§ 15.2.2~~ The Control Estimate shall include:

- ~~1~~ the documents enumerated in Article 6, including all Modifications thereto;
- ~~2~~ a list of the assumptions made by the Contractor in the preparation of the Control Estimate to supplement the information provided by the Owner and contained in the Contract Documents;
- ~~3~~ a statement of the estimated Cost of the Work organized by trade categories or systems and the Contractor's Fee;
- ~~4~~ a project schedule upon which the Control Estimate is based, indicating proposed Subcontractors, activity sequences and durations, milestone dates for receipt and approval of pertinent information, schedule of shop drawings and samples, procurement and delivery of materials or equipment the Owner's occupancy requirements, and the date of Substantial Completion; and
- ~~5~~ a list of any contingency amounts included in the Control Estimate for further development of design and construction.

~~§ 15.2.3~~ When the Control Estimate is acceptable to the Owner and Architect, the Owner shall acknowledge it in writing. The Owner's acceptance of the Control Estimate does not imply that the Control Estimate constitutes a ~~Guaranteed Maximum Price~~.

~~§ 15.2.4~~ The Contractor shall develop and implement a detailed system of cost control that will provide the Owner and Architect with timely information as to the anticipated total Cost of the Work. The cost control system shall compare the Control Estimate with the actual cost for activities in progress and estimates for uncompleted tasks and proposed changes. This information shall be reported to the Owner, in writing, no later than the Contractor's first Application for Payment and shall be revised and submitted with each Application for Payment.

~~§ 15.2.5~~ The Owner shall authorize preparation of revisions to the Contract Documents that incorporate the agreed-upon assumptions contained in the Control Estimate. The Owner shall promptly furnish such revised Contract Documents to the Contractor. The Contractor shall notify the Owner and Architect of any inconsistencies between the Control Estimate and the revised Contract Documents.

~~§ 15.3 Applications for Payment~~

~~§ 15.3.1~~ At least ten days before the date established for each progress payment, the Contractor shall submit to the Architect and the Owner an itemized Application for Payment prepared in accordance with the schedule of values, if required under Section 15.1, for completed portions of the Work. The application shall be notarized, if required; be supported by all data substantiating the Contractor's right to payment that the Owner or Architect require; and shall reflect retainage if provided for in the Contract Documents; and include any revised cost control information required by Section 15.2.4. Applications for Payment shall not include requests for payment for portions of the Work for which the Contractor does not intend to pay a Subcontractor or supplier, unless such Work has been performed by others whom the Contractor intends to pay.

~~§ 15.3.2~~ With each Application for Payment where the Contract Sum is based upon the Cost of the Work, or the Cost of the Work with a ~~Guaranteed Maximum Price~~, the Contractor shall submit payrolls, petty cash accounts, receipted invoices or invoices with check vouchers attached, and any other evidence required by the Owner to demonstrate that cash disbursements already made by the Contractor on account of the Cost of the Work equal or exceed progress payments already received by the Contractor plus payrolls for the period covered by the present Application for Payment, less that portion of the progress payments attributable to the Contractor's Fee.

§ 15.32.3.2 Payments shall be made on account of materials and equipment delivered and suitably stored at the site for subsequent incorporation in the Work. If approved in advance by the Owner, payment may similarly be made for materials and equipment stored, and protected from damage, off the site at a location agreed upon in writing.

§ 15.32.4.3 The Contractor warrants that title to all Work covered by an Application for Payment will pass to the Owner no later than the time of payment. The Contractor further warrants that upon submittal of an Application for Payment all Work for which Certificates for Payment have been previously issued and payments received from the Owner shall, to the best of the Contractor's knowledge, information and belief, be free and clear of liens, claims, security interests or other encumbrances adverse to the Owner's interests.

§ 15.4.3 Certificates for Payment

§ 15.43.1 The Architect ~~and the Owner~~ will, within seven days after receipt of the Contractor's Application for Payment, either issue ~~to the Owner~~ a Certificate for Payment, with a copy to the Contractor, for such amount as the Architect ~~and the Owner~~ determines is properly due, or notify the Contractor ~~and Owner~~ of the Architect's ~~and the Owner's~~ reasons for withholding certification in whole or in part as provided in Section 15.43.3.

§ 15.43.2 The issuance of a Certificate for Payment will constitute a representation by the Architect ~~to the~~ ~~and the~~ Owner, based on the Architect's ~~and the Owner's~~ evaluations of the Work and the data in the Application for Payment, that, to the best of the Architect's ~~and the Owner's~~ knowledge, information, and belief, the Work has progressed to the point indicated, the quality of the Work is in accordance with the Contract Documents, and the Contractor is entitled to payment in the amount certified. The foregoing representations are subject to an evaluation of the Work for conformance with the Contract Documents upon Substantial Completion, to results of subsequent tests and inspections, to correction of minor deviations from the Contract Documents prior to completion and to specific qualifications expressed by the Architect ~~and the Owner~~. However, the issuance of a Certificate for Payment will not be a representation that the Architect ~~and the Owner~~ have (1) made exhaustive or continuous on-site inspections to check the quality or quantity of the Work; (2) reviewed construction means, methods, techniques, sequences, or procedures; (3) reviewed copies of requisitions received from Subcontractors and suppliers and other data requested by the Owner to substantiate the Contractor's right to payment; or (4) made examination to ascertain how or for what purpose the Contractor has used money previously paid on account of the Contract Sum.

§ 15.43.3 The Architect ~~and the Owner~~ may withhold a Certificate for Payment in whole or in part, to the extent reasonably necessary to protect the Owner, if in the Architect's ~~and the Owner's~~ opinion the representations ~~to the Owner~~ required by Section 15.43.2 cannot be made. If the Architect ~~and the Owner~~ ~~is~~ ~~are~~ unable to certify payment in the amount of the Application, the Architect ~~and the Owner~~ will notify the Contractor ~~and Owner~~ as provided in Section 15.43.1. If the Contractor and the Architect ~~and the Owner~~ cannot agree on a revised amount, the Architect ~~and the Owner~~ will promptly issue a Certificate for Payment for the amount for which the Architect ~~and the Owner~~ ~~is~~ ~~are~~ able to make such representations ~~to the Owner~~. The Architect ~~and the Owner~~ may also withhold a Certificate for Payment or, because of subsequently discovered evidence, may nullify the whole or a part of a Certificate for Payment previously issued, to such extent as may be necessary in the Architect's ~~and the Owner's~~ opinion to protect the Owner from loss for which the Contractor is responsible, including loss resulting from acts and omissions described in Section 9.2.2, because of

- .1 defective Work not remedied;
- .2 third-party claims filed or reasonable evidence indicating probable filing of such claims unless security acceptable to the Owner is provided by the Contractor;
- .3 failure of the Contractor to make payments properly to Subcontractors or suppliers for labor, materials or equipment;
- .4 reasonable evidence that the Work cannot be completed for the unpaid balance of the Contract Sum;
- .5 damage to the Owner or a Separate Contractor;
- .6 reasonable evidence that the Work will not be completed within the Contract Time and that the unpaid balance would not be adequate to cover actual or liquidated damages for the anticipated delay; or
- .7 repeated failure to carry out the Work in accordance with the Contract Documents.

When the above reasons for withholding certification are removed, certification will be made for amounts previously withheld.

§ 15.43.4 When ~~either party~~ the Contractor disputes the Architect's ~~and the Owner's~~ decision regarding a Certificate for Payment under Section 15.43.3, in whole or in part, that party may submit a Claim in accordance with Article 21.

§ 15.5.4 Progress Payments

§ 15.54.1 The Contractor shall pay each Subcontractor, no later than ~~seven~~fourteen days after receipt of payment from the Owner, the amount to which the Subcontractor is entitled, reflecting percentages actually retained from payments to the Contractor on account of the Subcontractor's portion of the Work. The Contractor shall, by appropriate agreement with each Subcontractor, require each Subcontractor to make payments to sub-subcontractors in a similar manner.

§ 15.54.2 Neither the Owner nor Architect shall have an obligation to pay or see to the payment of money to a Subcontractor or supplier except as may otherwise be required by law.

§ 15.54.3 A Certificate for Payment, a progress payment, or partial or entire use or occupancy of the Project by the Owner shall not constitute acceptance of Work not in accordance with the Contract Documents.

§ 15.54.4 Provided the Owner has fulfilled its payment obligations under the Contract Documents, the Contractor shall defend and indemnify the Owner from all loss, liability, damage or expense, including reasonable attorney's fees and litigation expenses, arising out of any lien claim or other claim for payment by any Subcontractor or supplier of any tier. Upon receipt of notice of a lien claim or other claim for payment, the Owner shall notify the Contractor. If approved by the applicable court, when required, the Contractor may substitute a surety bond for the property against which the lien or other claim for payment has been asserted.

§ 15.6.5 Substantial Completion

§ 15.65.1 Substantial Completion is the stage in the progress of the Work when the Work or designated portion thereof is sufficiently complete in accordance with the Contract Documents so that the Owner can occupy or utilize the Work for its intended use and only minor items which can be corrected or completed without any material interference with the Owner's use of the Work remaining to be corrected or completed.

§ 15.65.2 When the Contractor considers that the Work, or a portion thereof which the Owner agrees to accept separately, is substantially complete, the Contractor shall prepare and submit to the Architect and the Owner a comprehensive list of items to be completed or corrected prior to final payment. Failure to include an item on such list does not alter the responsibility of the Contractor to complete all Work in accordance with the Contract Documents.

§ 15.65.3 Upon receipt of the Contractor's list, the Architect and the Owner will make an inspection to determine whether the Work or designated portion thereof is substantially complete. When the Architect and the Owner determines that the Work or designated portion thereof is substantially complete, the Architect and the Owner will issue a Certificate of Substantial Completion which shall establish the date of Substantial Completion; establish responsibilities of the Owner and Contractor for security, maintenance, heat, utilities, damage to the Work and insurance; and fix the time within which the Contractor shall finish all items on the list accompanying the Certificate. Warranties required by the Contract Documents shall commence on the date of Substantial Completion of the Work or designated portion thereof unless otherwise provided in the Certificate of Substantial Completion. In the event of a dispute regarding whether the Contractor's Work is substantially complete, the dispute shall be resolved pursuant to Article 21.

§ 15.65.4 The Certificate of Substantial Completion shall be submitted to the Owner and Contractor for their written acceptance of responsibilities assigned to them in the Certificate. Upon such acceptance and consent of surety, if any, the Owner shall make payment of retainage applying to the Work or designated portion thereof. Such payment shall be adjusted for Work that is incomplete or not in accordance with the requirements of the Contract Documents.

§ 15.7.6 Final Completion and Final Payment

§ 15.76.1 Upon receipt of the Contractor's notice that the Work is ready for final inspection and acceptance and upon receipt of a final Application for Payment, the Architect and the Owner will promptly make such inspection and, when the Architect and the Owner finds the Work acceptable under the Contract Documents and the Contract fully performed, the Architect and the Owner will promptly issue a final Certificate for Payment stating that to the best of the Architect's and the Owner's knowledge, information and belief, and on the basis of the Architect's and the Owner's on-site visits and inspections, the Work has been completed in accordance with the Contract Documents and that the entire balance found to be due the Contractor and noted in the final Certificate is due and payable. The

Architect's and the Owner's final Certificate for Payment will constitute a further representation that conditions stated in Section 15.76.2 as precedent to the Contractor's being entitled to final payment have been fulfilled.

§ 15.6.1A Final payment shall be made by the Owner to the Contractor when

- .1 the Contractor has fully performed the Contract except for the Contractor's responsibility to correct Work and to satisfy other requirements, if any, which extend beyond final payment;
- .2 the Architect and the Owner have issued the certification required by Subparagraph 15.4.1; and
- .3 the Contractor has delivered certain close-out items to the Owner, including but not limited to (1) all maintenance and operating manuals and as-built drawings; (2) any special guaranties or warranties required by the Contract Documents; (3) assignment of all guaranties and warranties from subcontractors, vendors, suppliers or manufacturers; and (4) a list of the names, addresses and telephone numbers of all subcontractors and any other persons providing guaranties and warranties.

§ 15.76.2 Final payment shall not become due until the Contractor has delivered to the Owner a complete release of all liens arising out of this Contract or receipts in full covering all labor, materials and equipment for which a lien could be filed, or a bond satisfactory to the Owner to indemnify the Owner against such lien. If such lien remains unsatisfied after payments are made, the Contractor shall refund to the Owner all money that the Owner may be compelled to pay in discharging such lien, including costs and reasonable attorneys' fees.

§ 15.76.3 The making of final payment shall constitute a waiver of claims by the Owner except those arising from

- .1 liens, claims, security interests or encumbrances arising out of the Contract and unsettled;
- .2 failure of the Work to comply with the requirements of the Contract Documents;
- .3 terms of special warranties required by the Contract Documents; or
- .4 audits performed by the Owner, if permitted by the Contract Documents, after final payment.

§ 15.76.4 Acceptance of final payment by the Contractor, a Subcontractor or supplier shall constitute a waiver of claims by that payee except those previously made in writing and identified by that payee as unsettled at the time of the final Application for Payment.

ARTICLE 16 PROTECTION OF PERSONS AND PROPERTY

§ 16.1 Safety Precautions and Programs

The Contractor shall be responsible for initiating, maintaining, and supervising all safety precautions and programs in connection with the performance of the Contract. The Contractor shall take reasonable precautions for safety of, and shall provide reasonable protection to prevent damage, injury, or loss to

- .1 employees on the Work and other persons who may be affected thereby;
- .2 the Work and materials and equipment to be incorporated therein, whether in storage on or off the site, under care, custody, or control of the Contractor, a Subcontractor, or a Sub-subcontractor; and
- .3 other property at the site or adjacent thereto, such as trees, shrubs, lawns, walks, pavements, roadways, structures and utilities not designated for removal, relocation, or replacement in the course of construction.

The Contractor shall comply with, and give notices required by, applicable laws, statutes, ordinances, codes, rules and regulations, and lawful orders of public authorities bearing on safety of persons and property and their protection from damage, injury, or loss. The Contractor shall promptly remedy damage and loss to property caused in whole or in part by the Contractor, a Subcontractor, a sub-subcontractor, or anyone directly or indirectly employed by any of them, or by anyone for whose acts they may be liable and for which the Contractor is responsible under Sections 16.1.2 and 16.1.3. The Contractor may make a claim for the cost to remedy the damage or loss to the extent such damage or loss is attributable to acts or omissions of the Owner or Architect or by anyone for whose acts either of them may be liable, and not attributable to the fault or negligence of the Contractor. The foregoing obligations of the Contractor are in addition to the Contractor's obligations under Section 9.15.

§ 16.2 Hazardous Materials and Substances

§ 16.2.1 The Contractor is responsible for compliance with the requirements of the Contract Documents regarding hazardous materials or substances. If the Contractor encounters a hazardous material or substance not addressed in the Contract Documents, and if reasonable precautions will be inadequate to prevent foreseeable bodily injury or death to persons resulting from a material or substance, including but not limited to asbestos or polychlorinated biphenyl

(PCB), encountered on the site by the Contractor, the Contractor shall, upon recognizing the condition, immediately stop Work in the affected area and notify the Owner and Architect of the condition. When the material or substance has been rendered harmless, Work in the affected area shall resume upon written agreement of the Owner and Contractor. By Change Order, the Contract Time shall be extended appropriately and the Contract Sum shall be increased in the amount of the Contractor's reasonable additional costs of shutdown, delay, and start-up.

§ 16.2.2 To the fullest extent permitted by law, the Owner shall indemnify and hold harmless the Contractor, Subcontractors, Architect, Architect's consultants, and agents and employees of any of them from and against claims, damages, losses, and expenses, including but not limited to attorneys' fees, arising out of or resulting from performance of the Work in the affected area, if in fact, the material or substance presents the risk of bodily injury or death as described in Section 16.2.1 and has not been rendered harmless, provided that such claim, damage, loss, or expense is attributable to bodily injury, sickness, disease or death, or to injury to or destruction of tangible property (other than the Work itself), except to the extent that such damage, loss, or expense is due to the fault or negligence of the party seeking indemnity.

§ 16.2.3 If, without negligence on the part of the Contractor, the Contractor is held liable by a government agency for the cost of remediation of a hazardous material or substance solely by reason of performing Work as required by the Contract Documents, the Owner shall indemnify the Contractor for all cost and expense thereby incurred.

ARTICLE 17 INSURANCE AND BONDS

§ 17.1 Contractor's Insurance

§ 17.1.1 The Contractor shall purchase and maintain insurance of the types and limits of liability, containing the endorsements, and subject to the terms and conditions, as described in this Section 17.1 or elsewhere in the Contract Documents. The Contractor shall purchase and maintain the insurance required by this Agreement from an insurance company or insurance companies lawfully authorized to issue insurance in the jurisdiction where the Project is located. The Contractor shall maintain the required insurance until the expiration of the period for correction of Work as set forth in Section 18.4, unless a different duration is stated below:

The Contractor shall provide written notification to the Owner of the cancellation or expiration of any insurance required by Section 17.1. The Contractor shall provide such written notice within five (5) business days of the date the Contractor is first aware that the cancellation or expiration is threatened or otherwise may occur, whichever comes first. ←→

§ 17.1.2 Commercial General Liability insurance for the Project written on an occurrence form with policy limits of not less than ~~«one million dollars»~~ (\$ ~~«1,000,000.00»~~)-) each occurrence, ~~«one million dollars»~~ (\$ ~~«1,000,000.00»~~)-) general aggregate, and ~~«one million dollars»~~ (\$ ~~«1,000,000.00»~~)-) aggregate for products-completed operations hazard, providing coverage for claims including

- .1 damages because of bodily injury, sickness or disease, including occupational sickness or disease, and death of any person;
- .2 personal and advertising injury;
- .3 damages because of physical damage to or destruction of tangible property, including the loss of use of such property;
- .4 bodily injury or property damage arising out of completed operations; and
- .5 the Contractor's indemnity obligations under Section 9.15.

§ 17.1.3 Automobile Liability covering vehicles owned by the Contractor and non-owned vehicles used by the Contractor, with policy limits of not less than ~~«one million dollars»~~ (\$ ~~«1,000,000.00»~~)-) per accident, for bodily injury, death of any person, and property damage arising out of the ownership, maintenance, and use of those motor vehicles along with any other statutorily required automobile coverage.

§ 17.1.4 The Contractor may achieve the required limits and coverage for Commercial General Liability and Automobile Liability through a combination of primary and excess or umbrella liability insurance, provided such primary and excess or umbrella insurance policies result in the same or greater coverage as those required under Section 17.1.2 and 17.1.3, and in no event shall any excess or umbrella liability insurance provide narrower coverage than the primary policy. The excess policy shall not require the exhaustion of the underlying limits only through the actual payment by the underlying insurers.

§ 17.1.5 Workers' Compensation at statutory limits.

§ 17.1.6 Employers' Liability with policy limits not less than ~~«one million dollars-» (\$ «1,000,000.00-»)~~ each accident, ~~«one million dollars-» (\$ «1,000,000.00-»)~~ each employee, and ~~«one million dollars-» (\$ «1,000,000.00-»)~~ policy limit.

~~§ 17.1.7 If the Contractor is required to furnish professional services as part of the Work, the Contractor shall procure Professional Liability insurance covering performance of the professional services, with policy limits of not less than « » (\$ « ») per claim and « » (\$ « ») in the aggregate.~~

~~§ 17.1.8 If the Work involves the transport, dissemination, use, or release of pollutants, the Contractor shall procure Pollution Liability insurance, with policy limits of not less than « » (\$ « ») per claim and « » (\$ « ») in the aggregate.~~

~~§ 17.1.9 Coverage under Sections 17.1.7 and 17.1.8 may be procured through a Combined Professional Liability and Pollution Liability insurance policy, with combined policy limits of not less than « » (\$ « ») per claim and « » (\$ « ») in the aggregate.~~

§ 17.1.40-8 The Contractor shall provide certificates of insurance acceptable to the Owner evidencing compliance with the requirements in this Section 17.1 at the following times: (1) prior to commencement of the Work; (2) upon renewal or replacement of each required policy of insurance; and (3) upon the Owner's written request. An additional certificate evidencing continuation of liability coverage, including coverage for completed operations, shall be submitted with the final Application for Payment and thereafter upon renewal or replacement of such coverage until the expiration of the period required by Section 17.1.1. The certificates will show the Owner and the Town of Hull as an additional insureds on the Contractor's Commercial General Liability and excess or umbrella liability policies.

§ 17.1.44-9 The Contractor shall disclose to the Owner any deductible or self-insured retentions applicable to any insurance required to be provided by the Contractor.

§ 17.1.42-10 To the fullest extent permitted by law, the Contractor shall cause the commercial liability coverage required by this Section 17.1 to include (1) the Owner, the Town of Hull, the Architect, and the Architect's Consultants as additional insureds for claims caused in whole or in part by the Contractor's negligent acts or omissions during the Contractor's operations; and (2) the Owner and the Town of Hull as an additional insureds for claims caused in whole or in part by the Contractor's negligent acts or omissions for which loss occurs during completed operations. The additional insured coverage shall be primary and non-contributory to any of the Owner's general liability insurance policies and shall apply to both ongoing and completed operations. To the extent commercially available, the additional insured coverage shall be no less than that provided by Insurance Services Office, Inc. (ISO) forms CG 20 10 07 04, CG 20 37 07 04, and, with respect to the Architect and the Architect's Consultants, CG 20 32 07 04.

§ 17.1.43-11 Within ~~three-ten (3-10)~~ business days of the date the Contractor becomes aware of an impending or actual cancellation or expiration of any insurance required by this Section 17.1, the Contractor shall provide written notice to the Owner of such impending or actual cancellation or expiration. Upon receipt of notice from the Contractor, the Owner shall, unless the lapse in coverage arises from an act or omission of the Owner, have the right to stop the Work until the lapse in coverage has been cured by the procurement of replacement coverage by the Contractor. The furnishing of notice by the Contractor shall not relieve the Contractor of any contractual obligation to provide any required coverage.

§ 17.1.44-12 Other Insurance Provided by the Contractor

(List below any other insurance coverage to be provided by the Contractor and any applicable limits.)

Coverage

Limits

§ 17.2 Owner's Insurance

§ 17.2.1 Owner's Liability Insurance

The Owner shall be responsible for purchasing and maintaining the Owner's usual liability insurance.

§ 17.2.2 Property Insurance

§ 17.2.2.1 The Owner shall purchase and maintain, from an insurance company or insurance companies lawfully authorized to issue insurance in the jurisdiction where the Project is located, property insurance written on a builder's risk "all-risks" completed value or equivalent policy form and sufficient to cover the total value of the entire Project on a replacement cost basis. The Owner's property insurance coverage shall be no less than the amount of the initial Contract Sum, plus the value of subsequent Modifications and labor performed or materials or equipment supplied by others. The property insurance shall be maintained until Substantial Completion and thereafter as provided in Section 17.2.2.2, unless otherwise provided in the Contract Documents or otherwise agreed in writing by the parties to this Agreement. This insurance shall include the interests of the Owner, Contractor, Subcontractors, and Sub-subcontractors in the Project as insureds. This insurance shall include the interests of mortgagees as loss payees.

§ 17.2.2.2 Unless the parties agree otherwise, upon Substantial Completion, the Owner shall continue the insurance required by Section 17.2.2.1 or, if necessary, replace the insurance policy required under Section 17.2.2.1 with property insurance written for the total value of the Project that shall remain in effect until expiration of the period for correction of the Work set forth in Section 18.4.

§ 17.2.2.3 If the insurance required by this Section 17.2.2 is subject to deductibles or self-insured retentions, the Owner shall be responsible for all loss not covered because of such deductibles or retentions.

§ 17.2.2.4 If the Work involves remodeling an existing structure or constructing an addition to an existing structure, the Owner shall purchase and maintain, until the expiration of the period for correction of Work as set forth in Section 18.4, "all-risks" property insurance, on a replacement cost basis, protecting the existing structure against direct physical loss or damage, notwithstanding the undertaking of the Work. The Owner shall be responsible for all co-insurance penalties.

§ 17.2.2.5 Prior to commencement of the Work, the Owner shall secure the insurance, and provide evidence of the coverage, required under this Section 17.2.2 and, upon the Contractor's request, provide a copy of the property insurance policy or policies required by this Section 17.2.2. The copy of the policy or policies provided shall contain all applicable conditions, definitions, exclusions, and endorsements.

§ 17.2.2.6 Within three (3) business days of the date the Owner becomes aware of an impending or actual cancellation or expiration of any insurance required by this Section 17.2.2, the Owner shall provide notice to the Contractor of such impending or actual cancellation or expiration. Unless the lapse in coverage arises from an act or omission of the Contractor: (1) the Contractor, upon receipt of notice from the Owner, shall have the right to stop the Work until the lapse in coverage has been cured by the procurement of replacement coverage by either the Owner or the Contractor; (2) the Contract Time and Contract Sum shall be equitably adjusted; and (3) the Owner waives all rights against the Contractor, Subcontractors, and Sub-subcontractors to the extent any loss to the Owner would have been covered by the insurance had it not expired or been cancelled. If the Contractor purchases replacement coverage, the cost of the insurance shall be charged to the Owner by an appropriate Change Order. The furnishing of notice by the Owner shall not relieve the Owner of any contractual obligation to provide required insurance.

§ 17.2.2.7 Waiver of Subrogation

§ 17.2.2.7.1 The Owner and Contractor waive all rights against (1) each other and any of their subcontractors, sub-subcontractors, agents, and employees, each of the other; (2) the Architect and Architect's consultants; and (3) Separate Contractors, if any, and any of their subcontractors, sub-subcontractors, agents, and employees, for damages caused by fire, or other causes of loss, to the extent those losses are covered by property insurance required by this Agreement or other property insurance applicable to the Project, except such rights as they have to proceeds of such insurance. The Owner or Contractor, as appropriate, shall require similar written waivers in favor of the individuals and entities identified above from the Architect, Architect's consultants, Separate Contractors, subcontractors, and sub-subcontractors. The policies of insurance purchased and maintained by each person or entity agreeing to waive claims pursuant to this Section 17.2.2.7 shall not prohibit this waiver of subrogation. This waiver of subrogation shall be effective as to a person or entity (1) even though that person or entity would otherwise have a duty of indemnification, contractual or otherwise, (2) even though that person or entity did not pay the insurance premium directly or indirectly, or (3) whether or not the person or entity had an insurable interest in the damaged property.

§ 17.2.2.7.2 If during the Project construction period the Owner insures properties, real or personal or both, at or adjacent to the site by property insurance under policies separate from those insuring the Project, or if after final payment property insurance is to be provided on the completed Project through a policy or policies other than those insuring the Project during the construction period, to the extent permissible by such policies, the Owner waives all rights in accordance with the terms of Section 17.2.2.7.1 for damages caused by fire or other causes of loss covered by this separate property insurance.

§ 17.2.2.8 A loss insured under the Owner's property insurance shall be adjusted by the Owner as fiduciary and made payable to the Owner as fiduciary for the insureds, as their interests may appear, subject to requirements of any applicable mortgagee clause. The Owner shall pay the Architect and Contractor their just shares of insurance proceeds received by the Owner, and by appropriate agreements, written where legally required for validity, the Architect and Contractor shall make payments to their consultants and Subcontractors in similar manner.

§ 17.2.3 Other Insurance Provided by the Owner

(List below any other insurance coverage to be provided by the Owner and any applicable limits.)

Coverage	Limits
----------	--------

§ 17.3 Performance Bond and Payment Bond

§ 17.3.1 The Owner ~~shall have the right to require~~ the Contractor to furnish bonds covering faithful performance of the Contract (a performance bond) and payment of obligations arising thereunder (a payment bond) ~~as stipulated in the Contract Documents on the date of execution of the Contract in the amount of one hundred percent (100%) of the contract sum.~~

§ 17.3.2 Upon the request of any person or entity appearing to be a potential beneficiary of bonds covering payment of obligations arising under the Contract, the Contractor shall promptly furnish a copy of the bonds or shall authorize a copy to be furnished.

ARTICLE 18 CORRECTION OF WORK

§ 18.1 The Contractor shall promptly correct Work rejected by the Architect or Owner or failing to conform to the requirements of the Contract Documents, whether discovered before or after Substantial Completion and whether or not fabricated, installed, or completed. Costs of correcting such rejected Work, including additional testing and inspections, the cost of uncovering and replacement, and compensation for the Architect's services and expenses made necessary thereby, shall be at the Contractor's expense, ~~unless compensable under Section A.1.7.3 in Exhibit A, Determination of the Cost of the Work.~~

§ 18.2 In addition to the Contractor's obligations under Section 9.4, if, within one year after the date of Substantial Completion of the Work or designated portion thereof or after the date for commencement of warranties established under Section 15.6.3, or by terms of an applicable special warranty required by the Contract Documents, any of the Work is found to be not in accordance with the requirements of the Contract Documents, the Contractor shall correct it promptly after receipt of notice from the Owner to do so unless the Owner has previously given the Contractor a written acceptance of such condition. The Owner shall give such notice promptly after discovery of the condition. During the one-year period for correction of Work, if the Owner fails to notify the Contractor and give the Contractor an opportunity to make the correction, the Owner waives the rights to require correction by the Contractor and to make a claim for breach of warranty.

§ 18.3 If the Contractor fails to correct nonconforming Work within a reasonable time, the Owner may correct it in accordance with Section 8.3.

§ 18.4 The one-year period for correction of Work shall be extended with respect to portions of Work first performed after Substantial Completion by the period of time between Substantial Completion and the actual completion of that portion of the Work.

§ 18.5 The one-year period for correction of Work shall not be extended by corrective Work performed by the Contractor pursuant to this Article 18.

ARTICLE 19 MISCELLANEOUS PROVISIONS

§ 19.1 Assignment of Contract

Neither party to the Contract shall assign the Contract without written consent of the other, except that the Owner may, without consent of the Contractor, assign the Contract to a lender providing construction financing for the Project if the lender assumes the Owner's rights and obligations under the Contract Documents. The Contractor shall execute all consents reasonably required to facilitate such assignment.

§ 19.2 Governing Law

The Contract shall be governed by the law of the place where the Project is located, excluding that jurisdiction's choice of law rules. ~~If the parties have selected arbitration as the method of binding dispute resolution, the Federal Arbitration Act shall govern Section 21.6.~~

§ 19.3 Tests and Inspections

Tests, inspections, and approvals of portions of the Work required by the Contract Documents or by applicable laws, statutes, ordinances, codes, rules and regulations, or lawful orders of public authorities shall be made at an appropriate time. Unless otherwise provided, the Contractor shall make arrangements for such tests, inspections, and approvals with an independent testing laboratory or entity acceptable to the Owner, or with the appropriate public authority, and shall bear all related costs of tests, inspections, and approvals. The Contractor shall give the Architect timely notice of when and where tests and inspections are to be made so that the Architect may be present for such procedures. The Owner shall bear costs of tests, inspections, or approvals that do not become requirements until after bids are received or negotiations concluded. The Owner shall directly arrange and pay for tests, inspections, or approvals where building codes or applicable laws or regulations so require.

§ 19.4 The Owner's representative:

(Name, address, email address and other information)

« »
« »
« »
« »
« »
« »
« »

§ 19.5 The Contractor's representative:

(Name, address, email address and other information)

« »
« »
« »
« »
« »
« »
« »

§ 19.6 Neither the Owner's nor the Contractor's representative shall be changed without ten days' prior notice to the other party.

ARTICLE 20 TERMINATION OF THE CONTRACT

§ 20.1 Termination by the Contractor

If the Architect and/or the Owner fails to certify payment as provided in Section 15.4.1 for a period of 30 days through no fault of the Contractor, or if the Owner fails to make payment as provided in Section 4.1.3 for a period of 30 days, the Contractor may, upon seven additional days' notice to the Owner and the Architect, terminate the Contract and recover from the Owner payment for Work executed, including reasonable overhead and profit, costs incurred by reason of such termination, and damages.

§ 20.2 Termination by the Owner for Cause

§ 20.2.1 The Owner may terminate the Contract if the Contractor

- .1 repeatedly refuses or fails to supply enough properly skilled workers or proper materials;

- 2 fails to make payment to Subcontractors for materials or labor in accordance with the respective agreements between the Contractor and the Subcontractors;
- 3 repeatedly disregards applicable laws, statutes, ordinances, codes, rules and regulations, or lawful orders of a public authority; or
- 4 otherwise is guilty of substantial breach of a provision of the Contract Documents.

§ 20.2.2 When any of the reasons described in Section 20.2.1 exists, the Owner, ~~upon certification by the Architect that sufficient cause exists to justify such action,~~ may, without prejudice to any other remedy the Owner may have and after giving the Contractor seven days' notice, terminate the Contract and take possession of the site and of all materials, equipment, tools, and construction equipment and machinery thereon owned by the Contractor and may finish the Work by whatever reasonable method the Owner may deem expedient. Upon request of the Contractor, the Owner shall furnish to the Contractor a detailed accounting of the costs incurred by the Owner in finishing the Work.

§ 20.2.3 When the Owner terminates the Contract for one of the reasons stated in Section 20.2.1, the Contractor shall not be entitled to receive further payment until the Work is finished.

§ 20.2.4 If the unpaid balance of the Contract Sum exceeds costs of finishing the Work, including compensation for the Architect's services and expenses made necessary thereby, and other damages incurred by the Owner and not expressly waived, such excess shall be paid to the Contractor. If such costs and damages exceed the unpaid balance, the Contractor shall pay the difference to the Owner. The amount to be paid to the Contractor or Owner, as the case may be, shall be certified by the Architect, upon application, and this obligation for payment shall survive termination of the Contract.

§ 20.3 Termination by the Owner for Convenience

The Owner may, at any time, terminate the Contract for the Owner's convenience and without cause. The Owner shall pay the Contractor for Work executed; and costs incurred by reason of such termination, including costs attributable to termination of Subcontracts; and a termination fee, if any, as follows:

(Insert the amount of or method for determining the fee payable to the Contractor by the Owner following a termination for the Owner's convenience, if any.)

« »

ARTICLE 21 CLAIMS AND DISPUTES

§ 21.1 Claims, disputes, and other matters in question arising out of or relating to this Contract, including those alleging an error or omission by the Architect but excluding those arising under Section 16.2, shall be referred initially to the Architect for decision. Such matters, except those waived as provided for in Section 21.11 and Sections 15.7.3 and 15.7.4, shall, after initial decision by the Architect or 30 days after submission of the matter to the Architect, be subject to mediation as a condition precedent to binding dispute resolution.

§ 21.2 Notice of Claims

§ 21.2.1 Claims by either the Owner or Contractor, where the condition giving rise to the Claim is first discovered prior to expiration of the period for correction of the Work set forth in Section 18.2, shall be initiated by notice to the Architect within 21 days after occurrence of the event giving rise to such Claim or within 21 days after the claimant first recognizes the condition giving rise to the Claim, whichever is later.

§ 21.2.2 Claims by either the Owner or Contractor, where the condition giving rise to the Claim is first discovered after expiration of the period for correction of the Work set forth in Section 18.2, shall be initiated by notice to the other party.

§ 21.3 Time Limits on Claims

The Owner and Contractor shall commence all claims and causes of action against the other and arising out of or related to the Contract in accordance with the requirements of the final dispute resolution method selected in this Agreement whether in contract, tort, breach of warranty, or otherwise, within the period specified by applicable law; ~~but in any case not more than 10 years after the date of Substantial Completion of the Work.~~ The Owner and Contractor waive all claims and causes of action not commenced in accordance with this Section 21.3.

§ 21.4 If a claim, dispute or other matter in question relates to or is the subject of a mechanic's lien, the party asserting such matter may proceed in accordance with applicable law to comply with the lien notice or filing deadlines.

§ 21.5 The parties shall endeavor to resolve their disputes by mediation which, unless the parties mutually agree otherwise, shall be administered by the American Arbitration Association in accordance with their Construction Industry Mediation Procedures in effect on the date of this Agreement. A request for mediation shall be made in writing, delivered to the other party to this Agreement, and filed with the person or entity administering the mediation. The request may be made concurrently with the binding dispute resolution but, in such event, mediation shall proceed in advance of binding dispute resolution proceedings, which shall be stayed pending mediation for a period of 60 days from the date of filing, unless stayed for a longer period by agreement of the parties or court order. If an arbitration is stayed pursuant to this Section, the parties may nonetheless proceed to the selection of the arbitrator(s) and agree upon a schedule for later proceedings.

§ 21.6 If the parties have selected arbitration as the method for binding dispute resolution in this Agreement, any claim, subject to, but not resolved by, mediation shall be subject to arbitration which, unless the parties mutually agree otherwise, shall be administered by the American Arbitration Association, in accordance with the Construction Industry Arbitration Rules in effect on the date of this Agreement. Demand for arbitration shall be made in writing, delivered to the other party to the Contract, and filed with the person or entity administering the arbitration. The award rendered by the arbitrator or arbitrators shall be final, and judgment may be entered upon it in accordance with applicable law in any court having jurisdiction thereof.

§ 21.7 Subject to the rules of the American Arbitration Association or other applicable arbitration rules, either party, at its sole discretion, may consolidate an arbitration conducted under this Agreement with any other arbitration to which it is a party provided that (1) the arbitration agreement governing the other arbitration permits consolidation; (2) the arbitrations to be consolidated substantially involve common questions of law or fact; and (3) the arbitrations employ materially similar procedural rules and methods for selecting arbitrator(s).

§ 21.8 Subject to the rules of the American Arbitration Association or other applicable arbitration rules, any party to an arbitration may include by joinder persons or entities substantially involved in a common question of law or fact whose presence is required if complete relief is to be accorded in arbitration provided that the party sought to be joined consents in writing to such joinder. Consent to arbitration involving an additional person or entity shall not constitute consent to arbitration of a Claim not described in the written Consent.

§ 21.9 The foregoing agreement to arbitrate and other agreements to arbitrate with an additional person or entity duly consented to by parties to this Agreement, shall be specifically enforceable under applicable law in any court having jurisdiction thereof.

§ 21.10 Continuing Contract Performance

Pending final resolution of a Claim, except as otherwise agreed in writing, the Contractor shall proceed diligently with performance of the Contract and the Owner shall continue to make payments in accordance with the Contract Documents.

§ 21.11 Waiver of Claims for Consequential Damages

The Contractor and Owner waive claims against each other for consequential damages arising out of or relating to this Contract. This mutual waiver includes

- .1 damages incurred by the Owner for rental expenses, for losses of use, income, profit, financing, business and reputation, and for loss of management or employee productivity or of the services of such persons; and
- .2 damages incurred by the Contractor for principal office expenses including the compensation of personnel stationed there, for losses of financing, business and reputation, and for loss of profit except anticipated profit arising directly from the Work.

This mutual waiver is applicable, without limitation, to all consequential damages due to either party's termination in accordance with Article 20. Nothing contained in this Section 21.11 shall be deemed to preclude an award of liquidated damages, when applicable, in accordance with the requirements of the Contract Documents.

This Agreement entered into as of the day and year first written above.

OWNER (Signature)

« »

Hull Redevelopment Authority

(Printed name and title)

CONTRACTOR (Signature)

« »

(Printed name and title)

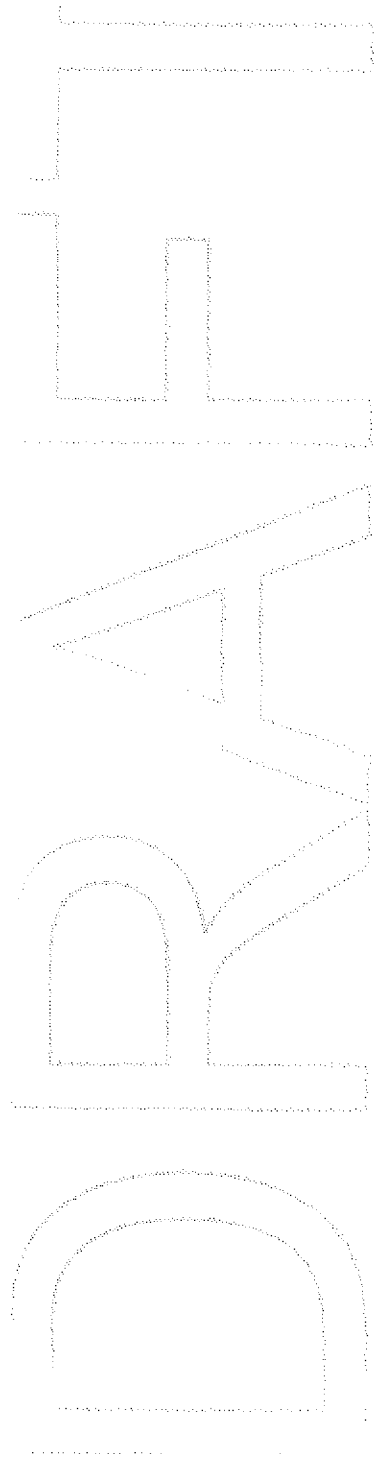

SUPPLEMENTARY GENERAL CONDITIONS
Nantasket Gazebo Project
Phase II Gazebo Construction
at Nantasket Beach, Hull, Massachusetts

These Supplementary General Conditions add to, modify, or delete from the Agreement. Where the Supplementary General Conditions add to the Agreement, the original provisions shall remain in effect and the supplementary provisions shall be considered as added thereto. Where the Supplementary General Conditions modify or delete provisions of the Agreement, the original provisions not explicitly altered or deleted shall remain in effect.

1. Statutory Reference: M. G. L. c. 30, § 39F. Construction contracts; assignment and subrogation; subcontractor defined; enforcement of claim for direct payment; deposit, reduction of disputed amounts.

(1) Every contract awarded pursuant to . . . [M. G. L. c. 30, § 39M] shall contain the following subparagraphs (a) through (h) and in each case those subparagraphs shall be binding between the general contractor and each subcontractor.

(a) Forthwith after the general contractor receives payment on account of a periodic estimate, the general contractor shall pay to each subcontractor the amount paid for the labor performed and the materials furnished by that subcontractor, less any amount specified in any court proceedings barring such payment and also less any amount claimed due from the subcontractor by the general contractor.

(b) Not later than the sixty-fifth day after each subcontractor substantially completes his work in accordance with the plans and specifications, the entire balance due under the subcontract less amounts retained by the awarding authority as the estimated cost of completing the incomplete and unsatisfactory items of work, shall be due the subcontractor; and the awarding authority shall pay that amount to the general contractor. The general contractor shall forthwith pay to the subcontractor the full amount received from the awarding authority less any amount specified in any court proceedings barring such payment and also less any amount claimed due from the subcontractor by the general contractor.

(c) Each payment made by the awarding authority to the general contractor pursuant to subparagraphs (a) and (b) of this paragraph for the labor performed and the materials furnished by a subcontractor shall be made to the general contractor for the account of that subcontractor; and the awarding authority shall take reasonable steps to compel the general contractor to make each such payment to each such subcontractor. If the awarding authority has received a demand for direct payment from a subcontractor for any amount which has already been included in a payment to the general contractor or which is to be included in a payment to the general contractor for payment to the subcontractor as provided in subparagraphs (a) and (b), the awarding authority shall act upon the demand as provided in this section.

(d) If, within seventy days after the subcontractor has substantially completed the subcontract work, the subcontractor has not received from the general contractor the balance due under the subcontract including any amount due for extra labor and materials furnished to the general contractor, less any amount retained by the awarding authority as the estimated cost of completing the incomplete and unsatisfactory items of work, the subcontractor may demand

direct payment of that balance from the awarding authority. The demand shall be by a sworn statement delivered to or sent by certified mail to the awarding authority, and a copy shall be delivered to or sent by certified mail to the general contractor at the same time. The demand shall contain a detailed breakdown of the balance due under the subcontract and also a statement of the status of completion of the subcontract work. Any demand made after substantial completion of the subcontract work shall be valid even if delivered or mailed prior to the seventieth day after the subcontractor has substantially completed the subcontract work. Within ten days after the subcontractor has delivered or so mailed the demand to the awarding authority and delivered or so mailed a copy to the general contractor, the general contractor may reply to the demand. The reply shall be by a sworn statement delivered to or sent by certified mail to the awarding authority and a copy shall be delivered to or sent by certified mail to the subcontractor at the same time. The reply shall contain a detailed breakdown of the balance due under the subcontract including any amount due for extra labor and materials furnished to the general contractor and of the amount due for each claim made by the general contractor against the subcontractor.

(e) Within fifteen days after receipt of the demand by the awarding authority, but in no event prior to the seventieth day after substantial completion of the subcontract work, the awarding authority shall make direct payment to the subcontractor of the balance due under the subcontract including any amount due for extra labor and materials furnished to the general contractor, less any amount (i) retained by the awarding authority as the estimated cost of completing the incomplete or unsatisfactory items of work, (ii) specified in any court proceedings barring such payment, or (iii) disputed by the general contractor in the sworn reply; provided, that the awarding authority shall not deduct from a direct payment any amount as provided in part (iii) if the reply is not sworn to, or for which the sworn reply does not contain the detailed breakdown required by subparagraph (d). The awarding authority shall make further direct payments to the subcontractor forthwith after the removal of the basis for deductions from direct payments made as provided in parts (i) and (ii) of this subparagraph.

(f) The awarding authority shall forthwith deposit the amount deducted from a direct payment as provided in part (iii) of subparagraph (e) in an interest-bearing joint account in the names of the general contractor and the subcontractor in a bank in Massachusetts selected by the awarding authority or agreed upon by the general contractor and the subcontractor and shall notify the general contractor and the subcontractor of the date of the deposit and the bank receiving the deposit. The bank shall pay the amount in the account, including accrued interest, as provided in an agreement between the general contractor and the subcontractor or as determined by decree of a court of competent jurisdiction.

(g) All direct payments and all deductions from demands for direct payments deposited in an interest-bearing account or accounts in a bank pursuant to subparagraph (f) shall be made out of amounts payable to the general contractor at the time of receipt of a demand for direct payment from a subcontractor and out of amounts which later become payable to the general contractor and in the order of receipt of such demands from subcontractors. All direct payments shall discharge the obligation of the awarding authority to the general contractor to the extent of such payment.

(h) The awarding authority shall deduct from payments to a general contractor amounts which, together with the deposits in interest-bearing accounts pursuant to subparagraph (f), are sufficient to satisfy all unpaid balances of demands for direct payment received from subcontractors. All

such amounts shall be earmarked for such direct payments, and the subcontractors shall have a right in such deductions prior to any claims against such amounts by creditors of the general contractor.

* * * *

(2) Any assignment by a subcontractor of the rights under this section to a surety company furnishing a bond under the provisions of section twenty-nine of chapter one hundred forty-nine shall be invalid. The assignment and subrogation rights of the surety to amounts included in a demand for direct payment which are in the possession of the awarding authority or which are on deposit pursuant to subparagraph (f) of paragraph (1) shall be subordinate to the rights of all subcontractors who are entitled to be paid under this section and who have not been paid in full.

(3) "Subcontractor" as used in this section (i) for contracts awarded as provided in sections forty-four A to forty-four H, inclusive, of chapter one hundred forty-nine shall mean a person who files a sub-bid and receives a subcontract as a result of that filed sub-bid or who is approved by the awarding authority in writing as a person performing labor or both performing labor and furnishing materials pursuant to a contract with the general contractor, (ii) for contracts awarded as provided in paragraph (a) of section thirty-nine M of chapter thirty shall mean a person approved by the awarding authority in writing as a person performing labor or both performing labor and furnishing materials pursuant to a contract with the general contractor, and (iii) for contracts with the commonwealth not awarded as provided in forty-four A to forty-four H, inclusive, of chapter one hundred forty-nine shall also mean a person contracting with the general contractor to supply materials used or employed in a public works project for a price in excess of five thousand dollars.

(4) A general contractor or a subcontractor shall enforce a claim to any portion of the amount of a demand for direct payment deposited as provided in subparagraph (f) of paragraph 1 by a petition in equity in the superior court against the other and the bank shall not be a necessary party. A subcontractor shall enforce a claim for direct payment or a right to require a deposit as provided in subparagraph (f) of paragraph 1 by a petition in equity in the superior court against the awarding authority and the general contractor shall not be a necessary party. Upon motion of any party the court shall advance for speedy trial any petition filed as provided in this paragraph. Sections fifty-nine and fifty-nine B of chapter two hundred thirty-one shall apply to such petitions. The court shall enter an interlocutory decree upon which execution shall issue for any part of a claim found due pursuant to sections fifty-nine and fifty-nine B and, upon motion of any party, shall advance for speedy trial the petition to collect the remainder of the claim. Any party aggrieved by such interlocutory decree shall have the right to appeal therefrom as from a final decree. The court shall not consolidate for trial the petition of any subcontractor with the petition of one or more subcontractors or the same general contract unless the court finds that a substantial portion of the evidence of the same events during the course of construction (other than the fact that the claims sought to be consolidated arise under the same general contract) is applicable to the petitions sought to be consolidated and that such consolidation will prevent unnecessary duplication of evidence. A decree in any such proceeding shall not include interest on the disputed amount deposited in excess of the interest earned for the period of any such deposit. No person except a subcontractor filing a demand for direct payment for which no funds due the general contractor are available for direct payment shall have a right to file a petition in court of equity against the awarding authority claiming a demand for direct payment is premature

and such subcontractor must file the petition before the awarding authority has made a direct payment to the subcontractor and has made a deposit of the disputed portion as provided in part (iii) of subparagraph (e) and in subparagraph (f) of paragraph (1).

(5) In any petition to collect any claim for which a subcontractor has filed a demand for direct payment the court shall, upon motion of the general contractor, reduce by the amount of any deposit of a disputed amount by the awarding authority as provided in part (iii) of subparagraph (e) and in subparagraph (f) of paragraph (1) any amount held under a trustee writ or pursuant to a restraining order or injunction.

2. Statutory Reference: M. G. L. c. 30, § 39I. Deviations from plans and specifications.

Every contractor having a contract for the construction, alteration, maintenance, repair or demolition of, or addition to, any public building or public works for the commonwealth, or of any political subdivision thereof, shall perform all the work required by such contract in conformity with the plans and specifications contained therein. No wilful and substantial deviation from said plans and specifications shall be made unless authorized in writing by the awarding authority or by the engineer or architect in charge of the work who is duly authorized by the awarding authority to approve such deviations. In order to avoid delays in the prosecution of the work required by such contract such deviation from the plans or specifications may be authorized by a written order of the awarding authority or such engineer or architect so authorized to approve such deviation. Within thirty days thereafter, such written order shall be confirmed by a certificate of the awarding authority stating: (1) If such deviation involves any substitution or elimination of materials, fixtures or equipment, the reasons why such materials, fixtures or equipment were included in the first instance and the reasons for substitution or elimination, and, if the deviation is of any other nature, the reasons for such deviation, giving justification therefor; (2) that the specified deviation does not materially injure the project as a whole; (3) that either the work substituted for the work specified is of the same cost and quality, or that an equitable adjustment has been agreed upon between the contracting agency and the contractor and the amount in dollars of said adjustment; and (4) that the deviation is in the best interest of the contracting authority.

Such certificate shall be signed under the penalties of perjury and shall be a permanent part of the file record of the work contracted for.

Whoever violates any provision of this section wilfully and with intent to defraud shall be punished by a fine of not more than five thousand dollars or by imprisonment for not more than six months, or both.

3. Statutory Reference: M. G. L. c. 30, § 39J. Public construction contracts; effect of decisions of contracting body or administrative board.

Notwithstanding any contrary provision of any contract for the construction, reconstruction, alteration, remodeling, repair or demolition of any public building or public works by the commonwealth, or by any county, city, town, district, board, commission or other public body, when the amount of the contract is more than five thousand dollars in the case of the commonwealth and more than two thousand dollars in the case of any county, city, town, district, board, commission or other public body, a decision, by the contracting body or by any administrative board, official or agency, or by any architect or engineer, on a dispute, whether of

fact or of law, arising under said contract shall not be final or conclusive if such decision is made in bad faith, fraudulently, capriciously, or arbitrarily is unsupported by substantial evidence, or is based upon error of law.

4. Statutory Reference: M. G. L. c. 30, § 39K. Public building construction contracts; payments.

Within fifteen days (30 days in the case of the commonwealth, including local housing authorities) after receipt from the contractor, at the place designated by the awarding authority if such a place is so designated, of a periodic estimate requesting payment of the amount due for the preceding month, the awarding authority will make a periodic payment to the contractor for the work performed during the preceding month and for the materials not incorporated in the work but delivered and suitably stored at the site (or at some location agreed upon in writing) to which the contractor has title or to which a subcontractor has title and has authorized the contractor to transfer title to the awarding authority, upon certification by the contractor that he is the lawful owner and that the materials are free from all encumbrances, but less (1) a retention based on its estimate of the fair value of its claims against the contractor and less (2) a retention for direct payments to subcontractors based on demands for same in accordance with the provisions of section thirty-nine F, and less (3) a retention not exceeding five per cent of the approved amount of the periodic payment. After the receipt of a periodic estimate requesting final payment and within sixty-five days after (a) the contractor fully completes the work or substantially completes the work so that the value of the work remaining to be done is, in the estimate of the awarding authority, less than one per cent of the original contract price, or (b) the contractor substantially completes the work and the awarding authority takes possession for occupancy, whichever occurs first, the awarding authority shall pay the contractor the entire balance due on the contract less (1) a retention based on its estimate of the fair value of its claims against the contractor and of the cost of completing the incomplete and unsatisfactory items of work and less (2) a retention for direct payments to subcontractors based on demands for same in accordance with the provisions of section thirty-nine F, or based on the record of payments by the contractor to the subcontractors under this contract if such record of payment indicates that the contractor has not paid subcontractors as provided in section thirty-nine F. If the awarding authority fails to make payment as herein provided, there shall be added to each such payment daily interest at the rate of three percentage points above the rediscount rate than charged by the Federal Reserve Bank of Boston commencing on the first day after said payment is due and continuing until the payment is delivered or mailed to the contractor; provided, that no interest shall be due, in any event, on the amount due on a periodic estimate for final payment until fifteen days (twenty-four days in the case of the commonwealth) after receipt of such a periodic estimate from the contractor, at the place designated by the awarding authority if such a place is so designated. The contractor agrees to pay to each subcontractor a portion of any such interest paid in accordance with the amount due each subcontractor.

The awarding authority may make changes in any periodic estimate submitted by the contractor and the payment due on said periodic estimate shall be computed in accordance with the changes so made, but such changes or any requirement for a corrected periodic estimate shall not affect the due date for the periodic payment or the date for the commencement of interest charges on the amount of the periodic payment computed in accordance with the changes made, as provided herein; provided, that the awarding authority may, within seven days after receipt, return to the

contractor for correction, any periodic estimate which is not in the required form or which contains computations not arithmetically correct and, in that event, the date of receipt of such periodic estimate shall be the date of receipt of the corrected periodic estimate in proper form and with arithmetically correct computations. The date of receipt of a periodic estimate received on a Saturday shall be the first working day thereafter. The provisions of section thirty-nine G shall not apply to any contract for the construction, reconstruction, alteration, remodeling, repair or demolition of any public building to which this section applies.

All periodic estimates shall be submitted to the awarding authority, or to its designee as set forth in writing to the contractor, and the date of receipt by the awarding authority or its designee shall be marked on the estimate. All periodic estimates shall contain a separate item for each filed subtrade and each sub-subtrade listed in sub-bid form as required by specifications and a column listing the amount paid to each subcontractor and sub-subcontractor as of the date the periodic estimate is filed. The person making payment for the awarding authority shall add the daily interest provided for herein to each payment for each day beyond the due date based on the date of receipt marked on the estimate.

A certificate of the architect to the effect that the contractor has fully or substantially completed the work shall, subject to the provisions of section thirty-nine J, be conclusive for the purposes of this section.

Notwithstanding the provisions of this section, at any time after the value of the work remaining to be done is, in the estimation of the awarding authority, less than 1 per cent of the adjusted contract price, or the awarding authority has determined that the contractor has substantially completed the work and the awarding authority has taken possession for occupancy, the awarding authority may send to the general contractor by certified mail, return receipt requested, a complete and final list of all incomplete and unsatisfactory work items, including, for each item on the list, a good faith estimate of the fair and reasonable cost of completing such item. The general contractor shall then complete all such work items within 30 days of receipt of such list or before the contract completion date, whichever is later. If the general contractor fails to complete all incomplete and unsatisfactory work items within 45 days after receipt of such items furnished by the awarding authority or before the contract completion date, whichever is later, subsequent to an additional 14 days' written notice to the general contractor by certified mail, return receipt requested, the awarding authority may terminate the contract and complete the incomplete and unsatisfactory work items and charge the cost of same to the general contractor and such termination shall be without prejudice to any other rights or remedies the awarding authority may have under the contract. The awarding authority shall note any such termination in the evaluation form to be filed by the awarding authority pursuant to the provisions of section 44D of chapter 149.

5. Statutory Reference: M. G. L. c. 30, § 39L. Public construction work by foreign corporations; restrictions and reports.

The commonwealth and every county, city, town, district, board, commission or other public body which, as the awarding authority, requests proposals, bids or sub-bids for any work in the construction, reconstruction, alteration, remodeling, repair or demolition of any public building or other public works (1) shall not enter into a contract for the work with, and shall not approve

as a subcontractor furnishing labor and materials for a part of the work, a foreign corporation which has not filed with the awarding authority a certificate of the state secretary stating that the corporation has complied with requirements of section 15.03 of subdivision A of Part 15 of chapter 156D and the date of compliance, and further has filed all annual reports required by section 16.22 of subdivision B of Part 16 of said chapter 156D, and (2) shall report to the state secretary and to the department of corporations and taxation any foreign corporation performing work under such contract or subcontract, and any person, other than a corporation, performing work under such contract or subcontract, and residing or having a principal place of business outside the commonwealth.

6. Statutory Reference: M. G. L. c. 30, § 39N. Construction contracts; equitable adjustment in contract price for differing subsurface or latent physical conditions.

Every contract subject to . . . [M. G. L. c. 30, § 39M] shall contain the following paragraph in its entirety and an awarding authority may adopt reasonable rules or regulations in conformity with that paragraph concerning the filing, investigation and settlement of such claims:

If, during the progress of the work, the contractor or the awarding authority discovers that the actual subsurface or latent physical conditions encountered at the site differ substantially or materially from those shown on the plans or indicated in the contract documents either the contractor or the contracting authority may request an equitable adjustment in the contract price of the contract applying to work affected by the differing site conditions. A request for such an adjustment shall be in writing and shall be delivered by the party making such claim to the other party as soon as possible after such conditions are discovered. Upon receipt of such a claim from a contractor, or upon its own initiative, the contracting authority shall make an investigation of such physical conditions, and, if they differ substantially or materially from those shown on the plans or indicated in the contract documents or from those ordinarily encountered and generally recognized as inherent in work of the character provided for in the plans and contract documents and are of such a nature as to cause an increase or decrease in the cost of performance of the work or a change in the construction methods required for the performance of the work which results in an increase or decrease in the cost of the work, the contracting authority shall make an equitable adjustment in the contract price and the contract shall be modified in writing accordingly.

7. Statutory Reference: M. G. L. c. 30, § 39O. Contracts for construction and materials; suspension, delay or interruption due to order of awarding authority; adjustment in contract price; written claim.

Every contract subject to the provisions of [M. G. L. c. 30, § 39M] . . . shall contain the following provisions (a) and (b) in their entirety and, in the event a suspension, delay, interruption or failure to act of the awarding authority increases the cost of performance to any subcontractor, that subcontractor shall have the same rights against the general contractor for payment for an increase in the cost of his performance as provisions (a) and (b) give the general contractor against the awarding authority, but nothing in provisions (a) and (b) shall in any way change, modify or alter any other rights which the general contractor or the subcontractor may have against each other.

(a) The awarding authority may order the general contractor in writing to suspend, delay, or interrupt all or any part of the work for such period of time as it may determine to be appropriate for the convenience of the awarding authority; provided however, that if there is a suspension, delay or interruption for fifteen days or more or due to a failure of the awarding authority to act within the time specified in this contract, the awarding authority shall make an adjustment in the contract price for any increase in the cost of performance of this contract but shall not include any profit to the general contractor on such increase; and provided further, that the awarding authority shall not make any adjustment in the contract price under this provision for any suspension, delay, interruption or failure to act to the extent that such is due to any cause for which this contract provides for an equitable adjustment of the contract price under any other contract provisions.

(b) The general contractor must submit the amount of a claim under provision (a) to the awarding authority in writing as soon as practicable after the end of the suspension, delay, interruption or failure to act and, in any event, not later than the date of final payment under this contract and, except for costs due to a suspension order, the awarding authority shall not approve any costs in the claim incurred more than twenty days before the general contractor notified the awarding authority in writing of the act or failure to act involved in the claim.

8. Statutory Reference: M. G. L. c. 30, § 39P. Contracts for construction and materials; awarding authority's decisions on interpretation of specifications, etc.; time limit; notice.

Every contract subject to [M. G. L. c. 30, § 39M] which requires the awarding authority, any official, its architect or engineer to make a decision on interpretation of the specifications, approval of equipment, material or any other approval, or progress of the work, shall require that the decision be made promptly and, in any event, no later than thirty days after the written submission for decision; but if such decision requires extended investigation and study, the awarding authority, the official, architect or engineer shall, within thirty days after the receipt of the submission, give the party making the submission written notice of the reasons why the decision cannot be made within the thirty day period and the date by which the decision will be made.

9. Statutory Reference: M. G. L. c. 30, § 39R. Keeping and maintaining of books, records and accounts; statement of management on internal accounting control; financial statements; enforcement.

(a) The words defined herein shall have the meaning stated below whenever they appear in this section:

(1) "Contractor" means any person, corporation, partnership, joint venture, sole proprietorship, or other entity awarded a contract pursuant to sections thirty-eight A1/2 to thirty-eight O, inclusive, of chapter seven and any contract awarded or executed pursuant to section eleven C of chapter twenty-five A, section thirty-nine M of chapter thirty, or sections forty-four A to forty-four H, inclusive, of chapter one hundred and forty-nine, which is for an amount or estimated amount greater than one hundred thousand dollars.

(2) "Contract" means any contract awarded or executed pursuant to sections thirty-eight A1/2 to thirty-eight O, inclusive, of chapter seven and any contract awarded or executed pursuant to section eleven C of chapter twenty-five A, section thirty-nine M of chapter thirty, or sections forty-four A through forty-four H, inclusive, of chapter one hundred and forty-nine, which is for amount or estimated amount greater than one hundred thousand dollars.

(3) "Records" means books of original entry, accounts, checks, bank statements and all other banking documents, correspondence, memoranda, invoices, computer printouts, tapes, discs, papers and other documents or transcribed information of any type, whether expressed in ordinary or machine language.

(4) "Independent Certified Public Accountant" means a person duly registered in good standing and entitled to practice as a certified public accountant under the laws of the place of his residence or principal office and who is in fact independent. In determining whether an accountant is independent with respect to a particular person, appropriate consideration should be given to all relationships between the accountant and that person or any affiliate thereof. Determination of an accountant's independence shall not be confined to the relationships existing in connection with the filing of reports with the awarding authority.

(5) "Audit", when used in regard to financial statements, means an examination of records by an independent certified public accountant in accordance with generally accepted accounting principles and auditing standards for the purpose of expressing a certified opinion thereon, or, in the alternative, a qualified opinion or a declination to express an opinion for stated reasons.

(6) "Accountant's Report", when used in regard to financial statements, means a document in which an independent certified public accountant indicates the scope of the audit which he has made and sets forth his opinion regarding the financial statements taken as a whole with a listing of noted exceptions and qualifications, or an assertion to the effect that an overall opinion cannot be expressed. When an overall opinion cannot be expressed the reason therefor shall be stated. An accountant's report shall include as a part thereof a signed statement by the responsible corporate officer attesting that management has fully disclosed all material facts to the independent certified public accountant, and that the audited financial statement is a true and complete statement of the financial condition of the contractor.

(7) "Management", when used herein, means the chief executive officers, partners, principals or other person or persons primarily responsible for the financial and operational policies and practices of the contractor.

(8) Accounting terms, unless otherwise defined herein, shall have a meaning in accordance with generally accepted accounting principles and auditing standards.

(b) Subsection (a)(2) hereof notwithstanding, every agreement or contract awarded or executed pursuant to sections thirty-eight A1/2 to thirty-eight O, inclusive, of chapter seven, or eleven C of chapter twenty-five A, and pursuant to section thirty-nine M of chapter thirty or to section forty-four A through H, inclusive, of chapter one hundred and forty-nine, shall provide that:

(1) The contractor shall make, and keep for at least six years after final payment, books, records, and accounts which in reasonable detail accurately and fairly reflect the transactions and dispositions of the contractor, and

(2) until the expiration of six years after final payment, the office of inspector general, and the commissioner of capital asset management and maintenance shall have the right to examine any books, documents, papers or records of the contractor or of his subcontractors that directly pertain to, and involve transactions relating to, the contractor or his subcontractors, and

(3) if the agreement is a contract as defined herein, the contractor shall describe any change in the method of maintaining records or recording transactions which materially affect any statements filed with the awarding authority, including in his description the date of the change and reasons therefor, and shall accompany said description with a letter from the contractor's independent certified public accountant approving or otherwise commenting on the changes, and

(4) if the agreement is a contract as defined herein, the contractor has filed a statement of management on internal accounting controls as set forth in paragraph (c) below prior to the execution of the contract, and

(5) if the agreement is a contract as defined herein, the contractor has filed prior to the execution of the contracts and will continue to file annually, an audited financial statement for the most recent completed fiscal year as set forth in paragraph (d) below.

(c) Every contractor awarded a contract shall file with the awarding authority a statement of management as to whether the system of internal accounting controls of the contractor and its subsidiaries reasonably assures that:

(1) transactions are executed in accordance with management's general and specific authorization;

(2) transactions are recorded as necessary

i. to permit preparation of financial statements in conformity with generally accepted accounting principles, and

ii. to maintain accountability for assets;

(3) access to assets is permitted only in accordance with management's general or specific authorization; and

(4) the recorded accountability for assets is compared with the existing assets at reasonable intervals and appropriate action was taken with respect to any difference.

Every contractor awarded a contract shall also file with the awarding authority a statement prepared and signed by an independent certified public accountant, stating that he has examined the statement of management on internal accounting controls, and expressing an opinion as to

(1) whether the representations of management in response to this paragraph and paragraph (b) above are consistent with the result of management's evaluation of the system of internal accounting controls; and

(2) whether such representations of management are, in addition, reasonable with respect to transactions and assets in amounts which would be material when measured in relation to the applicant's financial statements.

(d) Every contractor awarded a contract by the commonwealth or by any political subdivision thereof shall annually file with the commissioner of capital asset management and maintenance during the term of the contract a financial statement prepared by an independent certified public accountant on the basis of an audit by such accountant. The final statement filed shall include the date of final payment. All statements shall be accompanied by an accountant's report. Such statements shall be made available to the awarding authority upon request.

(e) The office of inspector general, the commissioner of capital asset management and maintenance and any other awarding authority shall enforce the provisions of this section. The commissioner of capital asset management and maintenance may after providing an opportunity for the inspector general and other interested parties to comment, promulgate pursuant to the provisions of chapter thirty A such rules, regulations and guidelines as are necessary to effectuate the purposes of this section. Such rules, regulations and guidelines may be applicable to all awarding authorities. A contractor's failure to satisfy any of the requirements of this section may be grounds for debarment pursuant to section forty-four C of chapter one hundred and forty-nine.

(f) Records and statements required to be made, kept or filed under the provisions of this section shall not be public records as defined in section seven of chapter four and shall not be open to public inspection; provided, however, that such records and statements shall be made available pursuant to the provisions of clause (2) of paragraph (b).

10. Statutory Reference: M. G. L. c. 30, § 39S. Contracts for construction; requirements.

(a) As used in this section the word "person" shall mean any natural person, joint venture, partnership, corporation or other business or legal entity. Any person submitting a bid for, or signing a contract to work on, the construction, reconstruction, alteration, remodeling or repair of any public work by the commonwealth, or political subdivision thereof, or by any county, city, town, district, or housing authority, and estimated by the awarding authority to cost more than \$10,000, and any person submitting a bid for, or signing a contract to work on, the construction, reconstruction, installation, demolition, maintenance or repair of any building by a public agency, estimated to cost more than \$10,000, shall certify on the bid, or contract, under penalties of perjury, as follows:

(1) that he is able to furnish labor that can work in harmony with all other elements of labor employed or to be employed in the work; (2) that all employees to be employed at the worksite will have successfully completed a course in construction safety and health approved by the

United States Occupational Safety and Health Administration that is at least 10 hours in duration at the time the employee begins work and who shall furnish documentation of successful completion of said course with the first certified payroll report for each employee; and (3) that all employees to be employed in the work subject to this bid have successfully completed a course in construction safety and health approved by the United States Occupational Safety and Health Administration that is at least 10 hours in duration.

(b) Any employee found on a worksite subject to this section without documentation of successful completion of a course in construction safety and health approved by the United States Occupational Safety and Health Administration that is at least 10 hours in duration shall be subject to immediate removal.

(c) The attorney general, or his designee, shall have the power to enforce this section including the power to institute and prosecute proceedings in the superior court to restrain the award of contracts and the performance of contracts in all cases where, after investigation of the facts, he has made a finding that the award or performance has resulted in violation, directly or indirectly, of subsection (b), and he shall not be required to pay to the clerk of the court an entry fee in connection with the institution of the proceeding.

11. The Contractor shall comply with **M. G. L. c. 149, §§ 26-27H**. The prevailing wage schedule is found attached to the Invitation for Bid listing the prevailing minimum wage rates that must be paid to all workers employed in the Work. The Owner is not responsible for any error, omissions or misprints in the wage schedule. The wage schedule shall continue to be the minimum rate wages payable to workers employed in the Work throughout the term of the Agreement, subject to the exceptions contained in M. G. L. c. 149, §§ 26-27H. The Contractor shall not have any claim for extra compensation from the Owner if the actual wages paid to Workers employed in the Work exceeds the rates listed on the wage schedule or otherwise provided by law. The wage schedule must be posted in a conspicuous place at the work site for the life of the project in accordance with M.G.L. c. 149 § 27.

12. **Statutory Reference: M. G. L. c. 149, § 26. Public works; preference to veterans and citizens; wages.**

In the employment of mechanics and apprentices, teamsters, chauffeurs and laborers in the construction of public works by the commonwealth, or by a county, town, authority or district, or by persons contracting or subcontracting for such works, preference shall first be given to citizens of the commonwealth who have been residents of the commonwealth for at least six months at the commencement of their employment who are veterans as defined in clause Forty-third of section 7 of chapter 4 and who are qualified to perform the work to which the employment relates and, within such preference, preference shall be given to service-disabled veterans; and secondly, to citizens of the commonwealth generally who have been residents of the commonwealth for at least six months at the commencement of their employment, and if they cannot be obtained in sufficient numbers, then to citizens of the United States, and every contract for such work shall contain a provision to this effect. Each county, town or district in the construction of public works, or persons contracting or sub-contracting for such works, shall give preference to veterans and citizens who are residents of such county, town, authority or district

and, within such preference, preference shall be given to service-disabled veterans. The rate per hour of the wages paid to said mechanics and apprentices, teamsters, chauffeurs and laborers in the construction of public works shall not be less than the rate or rates of wages to be determined by the commissioner as hereinafter provided; provided, that the wages paid to laborers employed on said works shall not be less than those paid to laborers in the municipal service of the town or towns where said works are being constructed; provided, further, that where the same public work is to be constructed in two or more towns, the wages paid to laborers shall not be less than those paid to laborers in the municipal service of the town paying the highest rate; provided, further, that if, in any of the towns where the works are to be constructed, a wage rate or wage rates have been established in certain trades and occupations by collective agreements or understandings in the private construction industry between organized labor and employers, the rate or rates to be paid on said works shall not be less than the rates so established; provided further, that in towns where no such rate or rates have been so established, the wages paid to mechanics, teamsters, chauffeurs and laborers on public works, shall not be less than the wages paid to the employees in the same trades and occupations by private employers engaged in the construction industry. This section shall also apply to regular employees of the commonwealth or of a county, town, authority or district, when such employees are employed in the construction, addition to or alteration of public buildings for which special appropriations of more than one thousand dollars are provided. Payments by employers to health and welfare plans, pension plans and supplementary unemployment benefit plans under collective bargaining agreements or understandings between organized labor and employers shall be included for the purpose of establishing minimum wage rates as herein provided.

Permanent and temporary laborers employed by the state department of highways and by the metropolitan district commission shall receive such salary or compensation as may be fixed under and in accordance with sections forty-five to fifty inclusive of chapter thirty.

13. Statutory Reference: M. G. L. c. 149, § 27. List of jobs; classification; schedule of wages; penalty; civil action.

The commissioner shall prepare, for the use of such public officials or public bodies whose duty it shall be to cause public works to be constructed, a list of the several jobs usually performed on various types of public works upon which mechanics and apprentices, teamsters, chauffeurs and laborers are employed, including the transportation of gravel or fill to the site of said public works or the removal of surplus gravel or fill from such site. The commissioner shall classify said jobs, and he may revise such classification from time to time, as he may deem advisable. Prior to awarding a contract for the construction of public works, said public official or public body shall submit to the commissioner a list of the jobs upon which mechanics and apprentices, teamsters, chauffeurs and laborers are to be employed, and shall request the commissioner to determine the rate of wages to be paid on each job. Each year after the awarding of the contract, the public official or public body shall submit to the commissioner a list of the jobs upon which mechanics and apprentices and laborers are to be employed and shall request that the commissioner update the determination of the rate of wages to be paid on each job. The general contractor shall annually obtain updated rates from the public official or public body and no contractor or subcontractor shall pay less than the rates so established. Said rates shall apply to all persons engaged in transporting gravel or fill to the site of said public works or removing gravel

or fill from such site, regardless of whether such persons are employed by a contractor or subcontractor or are independent contractors or owner-operators. The commissioner, subject to the provisions of section twenty-six, shall proceed forthwith to determine the same, and shall furnish said official or public body with a schedule of such rate or rates of wages as soon as said determination shall have been made. In advertising or calling for bids for said works, the awarding official or public body shall incorporate said schedule in the advertisement or call for bids by an appropriate reference thereto, and shall furnish a copy of said schedule, without cost, to any person requesting the same. Said schedule shall be made a part of the contract for said works and shall continue to be the minimum rate or rates of wages for said employees during the life of the contract. Any person engaged in the construction of said works shall cause a legible copy of said schedule and subsequent updates to be kept posted in a conspicuous place at the site of said works during the life of the contract. An apprentice performing work on a project subject to this section shall maintain in his possession an apprentice identification card issued pursuant to section 11W of chapter 23. The aforesaid rates of wages in the schedule of wage rates shall include payments by employers to health and welfare plans, pension plans and supplementary unemployment benefit plans as provided in said section twenty-six, and such payments shall be considered as payments to persons under this section performing work as herein provided. Any employer engaged in the construction of such works who does not make payments to a health and welfare plan, a pension plan and a supplementary unemployment benefit plan, where such payments are included in said rates of wages, shall pay the amount of said payments directly to each employee engaged in said construction. Whoever shall pay less than said rate or rates of wages, including payments to health and welfare funds and pension funds, or the equivalent payment in wages, on said works to any person performing work within classifications as determined by the commissioner, and whoever, for himself, or as representative, agent or officer of another, shall take or receive for his own use or the use of any other person, as a rebate, refund or gratuity, or in any other guise, any part or portion of the wages, including payments to health and welfare funds and pension funds, or the equivalent payment in wages, paid to any such person for work done or service rendered on said public works, shall have violated this section and shall be punished or shall be subject to a civil citation or order as provided in section 27C. The president and treasurer of a corporation and any officers or agents having the management of such corporation shall also be deemed to be employers of the employees of any corporation within the meaning of sections 26 to 27B, inclusive.

Offers of restitution or payment of restitution shall not be considered in imposing such punishment.

When an investigation by the attorney general's office reveals that a contractor or subcontractor has violated this section by failing to pay said rate or rates of wages, including payments to health and welfare funds and pension funds, or the equivalent payment in wages, on said works to any person performing work within classifications as determined by the commissioner, or that a contractor or subcontractor has, for himself, or as representative, agent or officer of another, taken or received for his own use or the use of any other person, as a rebate, refund or gratuity, or in any other guise, any portion of the wages, including payments to health and welfare funds and pension funds, or the equivalent payment in wages, paid to any such person for work done or service rendered on said public works, the attorney general may, upon written notice to the contractor or subcontractor and the sureties of the contractor or subcontractor, and after a hearing

thereon, order work halted on the part of the contract on which such wage violations occurred, until the defaulting contractor or subcontractor has filed with the attorney general's office a bond in the amount of such penal sum as the attorney general shall determine, conditioned upon payment of said rate or rates of wages, including payments to health and welfare funds and pension funds, or the equivalent payment in wages, on said works to any person performing work within classifications as determined by the commissioner.

An employee claiming to be aggrieved by a violation of this section may, 90 days after the filing of a complaint with the attorney general, or sooner if the attorney general assents in writing, and within 3 years after the violation, institute and prosecute in his own name and on his own behalf, or for himself and for others similarly situated, a civil action for injunctive relief, for any damages incurred, and for any lost wages and other benefits. An employee so aggrieved who prevails in such an action shall be awarded treble damages, as liquidated damages, for any lost wages and other benefits and shall also be awarded the costs of the litigation and reasonable attorneys' fees.

14. Statutory Reference: M. G. L. c. 149, § 27B. Records of employees; payroll records; statements of compliance.

Every contractor, subcontractor or public body engaged in said public works project by an agency, executive office, department, board, commission, bureau, division or authority of the commonwealth or county, or municipality or any subdivision thereof to which sections twenty-seven and twenty-seven A apply shall keep a true and accurate record of all mechanics and apprentices, teamsters, chauffeurs and laborers employed thereon, showing the name, address and occupational classification of each such employee on said works, and the hours worked by, and the wages paid to, each such employee, and shall submit weekly to the awarding authority by mail, first class postage prepaid, or by electronic mail, certified payroll records that shall consist of a complete copy of those records accompanied by a statement signed by the employer that indicates (1) the records are correct; and (2) the rate of wages paid to each performing the work of mechanic, apprentice, teamsters, chauffeurs, and laborers, and shall promptly furnish to the attorney general or his representative, upon his request, a copy of said record, signed by the employer or his authorized agent under the penalties of perjury. For every week in which an apprentice is employed by a contractor, subcontractor or public body subject to this section, a photocopy of the apprentice's apprentice identification card, issued pursuant to section 11W of chapter 23, shall be attached to the records submitted under this section. Such records shall be open to inspection by any authorized representative of the department at any reasonable time, and as often as may be necessary. Every contractor and subcontractor required to keep such a record shall submit a copy of said record to the awarding authority directly on a weekly basis.

Each such contractor, subcontractor or public body shall preserve its payroll records for a period of three years from the date of completion of the contract.

Each such contractor, subcontractor or public body shall furnish to the awarding authority directly within fifteen days after completion of its portion of the work a statement, executed by the contractor, subcontractor or public body or by any authorized officer or employee of the

contractor, subcontractor or public body who supervises the payment of wages, in the following form:

statement of compliance

,
(insert year)

I,
(Name of signatory party)(Title)

do hereby state:

That I pay or supervise the payment of the persons employed by
on the

(Contractor, subcontractor or public body)(Building or project)

and that all mechanics and apprentices, teamsters, chauffeurs and laborers employed on said project have been paid in accordance with wages determined under the provisions of sections twenty-six and twenty-seven of chapter one hundred and forty-nine of the General Laws.

Signature

Title

The above-mentioned copies of payroll records and statements of compliance shall be available for inspection by any interested party filing a written request to the awarding authority for such inspection and copying.

15. The Contractor shall comply with M.G.L. c. 149, §§ 30 and 34 which provide that no laborer, workman, mechanic, foreman or inspector working within the Commonwealth in the employ of the Contractor, subcontractor or any other person doing or contracting to do whole or part of the Work will be required to work more than eight (8) hours in any one (1) day or more than forty-eight (48) hours in any one (1) week, or more than six (6) days in any one (1) week, except in cases of emergencies.

16. **Statutory Reference: M. G. L. c. 149, § 29. Bonds for payment for labor, materials, rentals or transportation charges; enforcement of claim; notice of claim; speedy trial, appeal, consolidation; dismissal; legal fees; posting statute.**

Officers or agents contracting in behalf of the commonwealth or in behalf of any county, city, town, district or other political subdivision of the commonwealth or other public instrumentality for the construction, reconstruction, alteration, remodeling, repair or demolition of public buildings or other public works when the amount of the contract is more than \$25,000 shall obtain security by bond in an amount not less than one half of the total contract price, for payment by the contractor and subcontractors for labor performed or furnished and materials used or employed therein, including lumber so employed which is not incorporated therein and is not wholly or necessarily consumed or made so worthless as to lose its identity, but only to the extent of its purchase price less its fair salvage value, and including also any material specially fabricated at the order of the contractor or subcontractor for use as a component part of said public building or other public work so as to be unsuitable for use elsewhere, even though such material has not been delivered and incorporated into the public building or public work, but only to the extent of its purchase price less its fair salvage value and only to the extent that such

specially fabricated material is in conformity with the contract, plans and specifications or any changes therein duly made; for payment of transportation charges for materials used or employed therein which are consigned to the contractor or to a subcontractor who has a direct contractual relationship with the contractor; for payment by such contractor and subcontractors of any sums due for the rental or hire of vehicles, steam shovels, rollers propelled by steam or other power, concrete mixers, tools and other appliances and equipment employed in such construction, reconstruction, alteration, remodeling, repair or demolition; for payment of transportation charges directly related to such rental or hire; and for payment by such contractor and subcontractors of any sums due trustees or other persons authorized to collect such payments from the contractor or subcontractors, based upon the labor performed or furnished as aforesaid, for health and welfare plans, supplementary unemployment benefit plans and other fringe benefits which are payable in cash and provided for in collective bargaining agreements between organized labor and the contractor or subcontractors; provided, that any such trustees or other persons authorized to collect such payments for health and welfare plans, supplementary unemployment benefit plans and other fringe benefits shall, subject to the following provisions, be entitled to the benefit of the security only in an amount based upon labor performed or furnished as aforesaid for a maximum of two hundred and forty consecutive calendar days.

In order to obtain the benefit of such bond for any amount claimed due and unpaid at any time, any claimant having a contractual relationship with the contractor principal furnishing the bond, who has not been paid in full for any amount claimed due for the labor, materials, equipment, appliances or transportation included in the paragraph (1) coverage within sixty-five days after the due date for same, shall have the right to enforce any such claim (a) by filing a petition in equity within one year after the day on which such claimant last performed the labor or furnished the labor, materials, equipment, appliances or transportation included in the claim and (b) by prosecuting the claim thereafter by trial in the superior court to final adjudication and execution for the sums justly due the claimant as provided in this section.

Any claimant having a contractual relationship with a subcontractor performing labor or both performing labor and furnishing materials pursuant to a contract with the general contractor but no contractual relationship with the contractor principal furnishing the bond shall have the right to enforce any such claim as provided in subparagraphs (a) and (b) of paragraph (2) only if such claimant gives written notice to the contractor principal within sixty-five days after the day on which the claimant last performed the labor or furnished the labor, materials, equipment, appliances or transportation included in the paragraphs (1) coverage, stating with substantial accuracy the amount claimed, the name of the party for whom such labor was performed or such labor, materials, equipment, appliances or transportation were furnished; provided, that any such claimant shall have the right to enforce any part of a claim covering specially fabricated material included in the paragraph (1) coverage only if such claimant has given the contractor principal written notice of the placement of the order and the amount thereof not later than twenty days after receiving the final approval in writing for the use of the material. The notices provided for in this paragraph (3) shall be served by mailing the same by registered or certified mail postage prepaid in an envelope addressed to the contractor principal at any place at which the contractor principal maintains an office or conducts his business, or at the contractor principal's residence, or in any manner in which civil process may be served.

Upon motion of any party, the court shall advance for speedy trial a petition to enforce a claim pursuant to this section. Sections fifty-nine and fifty-nine B of chapter two hundred thirty-one shall apply to petitions to enforce claims pursuant to this section. The court shall enter an interlocutory decree upon which execution shall issue for any part of a claim found due pursuant to said sections fifty-nine or fifty-nine B and shall, upon motion of any party, advance for speedy trial the petition to enforce the remainder of the claim. Any party aggrieved by such interlocutory decree shall have the right to appeal therefrom as from a final decree. The court shall not consolidate for trial the petition of any claimant under this section with the petition of one or more other claimants on the same bond, unless the court finds that a substantial portion of the evidence of the same events during the course of construction (other than the fact that the claims sought to be consolidated arise under the same general contract) is applicable to the petitions sought to be consolidated, and that such consolidation will prevent unnecessary duplication of evidence.

The court shall not dismiss any petition on the ground that it was filed before the sixty-fifth day after the day the claimant last performed the labor or furnished the labor, materials, equipment, appliances or transportation included in the claim, nor shall the court dismiss any petition on the ground that a claim involves more than one contract with the same party and that the one year period has elapsed as to any one contract; provided, that the court shall not enter a decree upon any claim or part thereof prior to the seventieth day after the day the claimant last performed the labor or furnished the labor, materials, equipment, appliances or transportation included in the claim.

A decree in favor of any claimant under this section shall include reasonable legal fees based upon the time spent and the results accomplished as approved by the court and such legal fees shall not in any event be less than published rate of any recommended fee schedule of a state-wide bar association or of a bar association in which the office of counsel for claimant is located, whichever is higher.

Any person employing persons on any public works hereinbefore referred to shall post conspicuously, at such place or places as will provide reasonable opportunity for all employees to read the same, a correct copy of this section. The attorney general shall enforce this paragraph.

17. Notwithstanding anything to the contrary expressed or implied in the Agreement, any of the powers, rights, and duties of the Architect may be exercised by the Owner, provided that the Owner shall be under no obligation to do so. The Owner may rely on the Architect for the performance and exercise of its rights and obligations hereunder and shall be presumed to rely on the Architect in the absence of an explicit written assumption by the Owner of any such rights and obligations, except that any approval required to be obtained by the Owner hereunder shall not be valid without the signature of the Owner. The Owner may explicitly overrule in writing any action, determination or decision of the Architect should the Owner chose to do so, except to the extent that the same would violate applicable law.